

Pressure transducers type E-ATR-7

analog, for open and closed loop systems

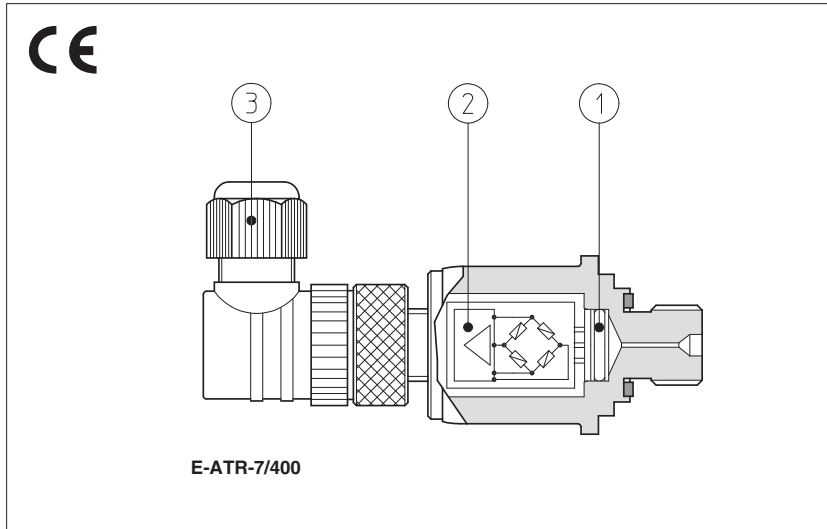

E-ATR-7 pressure transducers measure the static and dynamic pressure of the hydraulic fluid, supplying a voltage or current output signal.

The sensor is composed by a thin-film circuit ①, with high resistance to overloads and pressure peaks.

The integrated electronic circuit ② supplies an amplified voltage or current output signal, proportional to the hydraulic pressure, with thermal drift compensation.

E-ATR-7 equip pressure control digital proportional valves with integral transducer and electronics, TERS execution (see table G205).

They are also used in association with other Atos digital proportionals to perform closed loop pressure controls:

- variable displacement axial piston pumps, PE(R)S execution (see table A170)
- pressure control valves with remote pressure transducer, AERS execution (see table G205)
- directional control valves with additional closed loop pressure control, /SP and /SF options on TES(LES) execution (see table G210)

Features:

- Factory preset and calibrated
- Standard 4 pin M12 main connector ③
- IP67 protection degree
- CE mark to EMC and Low Voltage directives

1 MODEL CODE

E-ATR-7	/	400	/I	**
E-ATR-7 = Pressure transducer amplified type			Series number	
Pressure measuring range: 60 = 0 ÷ 60 bar 100 = 0 ÷ 100 bar 160 = 0 ÷ 160 bar 250 = 0 ÷ 250 bar 400 = 0 ÷ 400 bar		Options: - = with voltage output signal 0 ÷ 10 V I = with current output signal 4 ÷ 20 mA		

2 TRANSDUCER MAIN CHARACTERISTICS

Pressure measuring range	0 ÷ 60/100/160/250/400 bar; other values available on request note: negative pressure can damage the pressure transducer
Overload pressure	2 x full-scale
Burst pressure	5 x full-scale
Response time	≤ 2 ms
Operating temperature	-25 ÷ +85 °C (storage -40 ÷ +100 °C)
Thermal compensation	zero: ≤ ±0,025% FS/°C max; span: ≤ ±0,025% FS/°C max
Linearity and hysteresis range at 25°C	< ± 0,25% FS
Materials	wetted parts: stainless steel and FPM; seals: viton
Fluid Compatibility	hydraulic oil as per DIN51524..535 (for water-glycol, phosphate ester and skydrol® contact our tech.office)
Weight	approx. 55 g
Electronic supply	24 Vdc nominal; 12 ÷ 30 Vdc with I ≤ 50 mA (8 ÷ 30 Vdc for version /I)
Output signal	std: 0 ÷ 10 V (3 pins); load minimum 2 kΩ /I: 4 ÷ 20 mA (2 pins); current limitation: 32 mA
Wiring protections	against reverse polarity on power supply and short-circuit on output signal
Electromagnetic compatibility (EMC)	EN 61000-6-1, EN 61000-6-2, EN 61000-6-3, EN 61000-6-4
Vibration resistance	25 g according to DIN EN 60068-2-6 from 5 to 2000 Hz
Shock resistance	500 g / 1 ms / half-sinusoid according to DIN EN 60068-2-27
Protection class	IP 67
Hydraulic connection	1/4" GAS - DIN 3852
Connection	Type: plastic 4 pins M12 at 90° (DIN 43650-C) with cable gland type PG7 for cable max Ø 6 mm Protection: IP 67 according to DIN 40050; Insulation: according to VDE 0110-C

3 INSTALLATION AND COMMISSIONING

3.1 Warning

E-ATR-7 transducers have to be installed as near as possible to the point where the pressure must be measured, taking care that the oil flow is not turbulent.

3.2 Commissioning

Install the transducer in the hydraulic circuit

Switch-off the power supply before connecting and disconnecting the transducer connector as shown in scheme 5

4 OVERALL DIMENSIONS [mm]

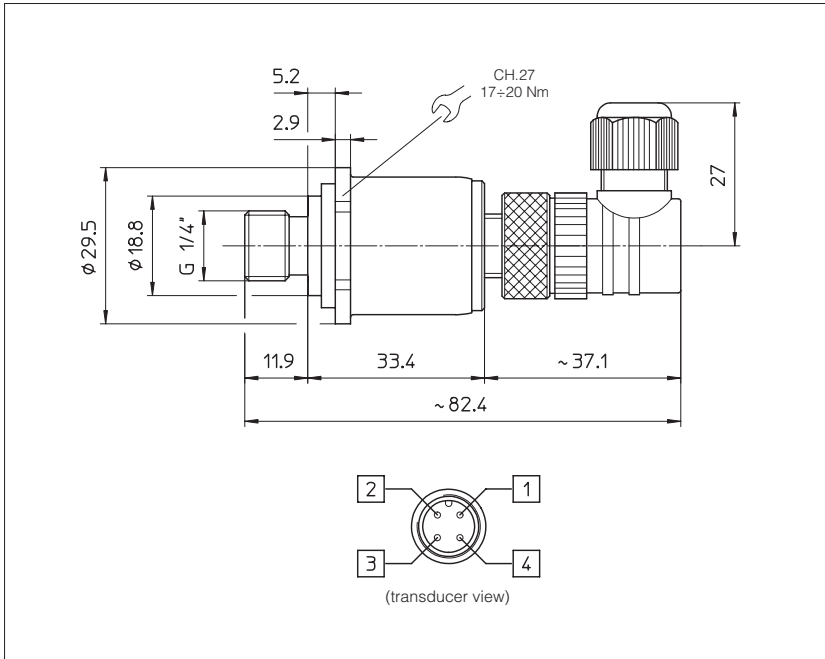

5 ELECTRONIC CONNECTIONS

