

Digital electronic drivers type E-RI-AES

integral-to-valve format, for proportional valves without transducer

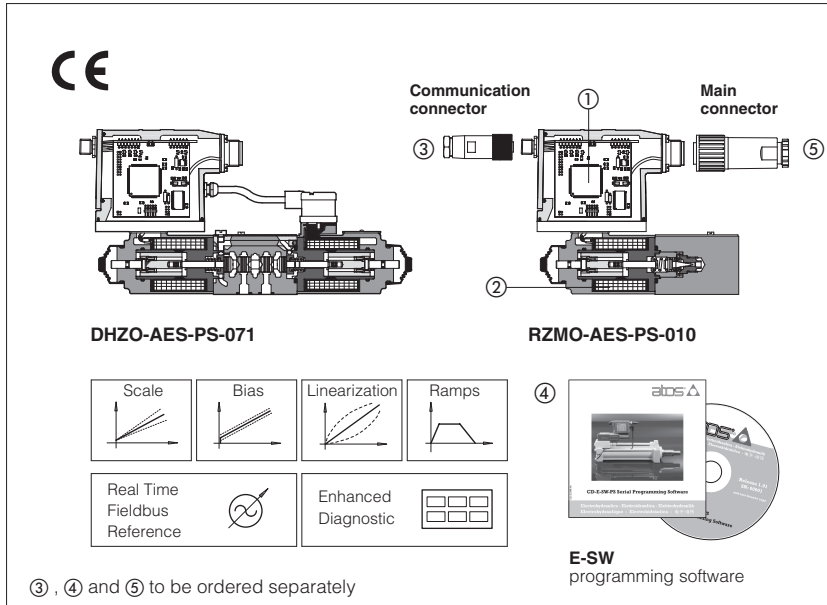

E-RI-AES integral digital drivers ① supply and control the current to the solenoid of Atos proportional valves without transducer, according to the electronic reference input signal. The solenoid ② proportionally transforms the current into a force, acting on the valve spool or poppet, against a reacting spring, thus providing the valve's hydraulic regulation.

E-RI-AES can drive one single or one double solenoid proportional valve.

The electronic main connector is fully interchangeable with the analog drivers one.

Digital communication interface ③ allows to program the drivers with the Atos PC software ④.

Drivers executions with fieldbus communication interface (CANopen or PROFIBUS DP) are available to program and command the valves directly by the machine control unit.

Electrical Features:

- Integral-to-valve digital electronic, functional parameters are factory preset for best performances
- Standard 7 pin main connector ⑤ for power supply, analog input reference and monitor signals
- /Z option 12 pin main connector for additional double power supply, enable and fault signals
- /I option for current reference / input signal
- 5 pin connector ③ for communication interface, at choice: serial -PS or fieldbus -BC and -BP
- IP67 protection degree
- CE mark to EMC and Low Voltage directives

Software Features:

- Setting of valve's functional parameters: bias, scale, ramps, dither
- Linearization function for the hydraulic regulation
- Setting of valve's dynamic response to optimize the application performances
- Range selection for the electronic refer. analog inputs: voltage or current (/I option)
- Complete diagnostics of driver status, solenoid and fault conditions
- Intuitive graphic interface

1 MODEL CODE

E-RI	- AE	S	- PS	- 01H	/*	**	/*
Integral electronic driver	AE = for proportional valves without transducer	S = digital executions	PS = Serial programming interface BC = CANopen programming interface BP = PROFIBUS DP programming interface	01H = for single solenoid proportional valves 05H = for double solenoid proportional valves		Series number	Set code (see note)

Options, see section 4:
I = current reference input (4÷20 mA)
Z = adds double power supply, enable and fault signals

Note: the set code identifies the correspondance between the digital integral driver and the relevant valve; it is assigned by Atos when the driver is ordered as spare part.

2 BLOCK DIAGRAM

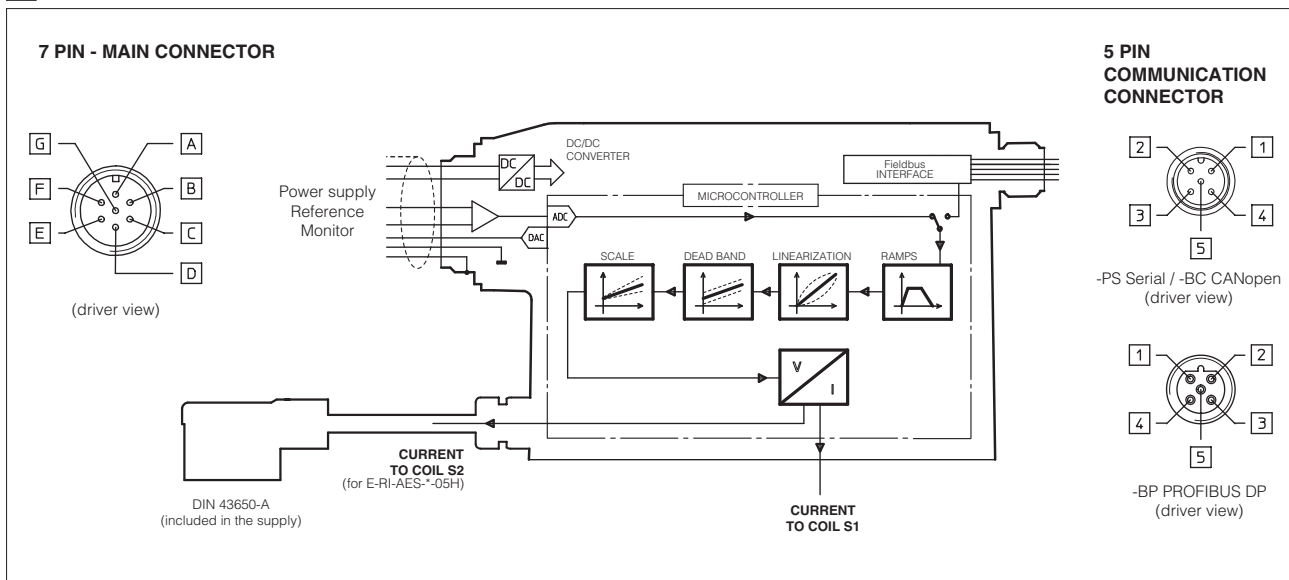

3 BLOCK DIAGRAM - /Z option

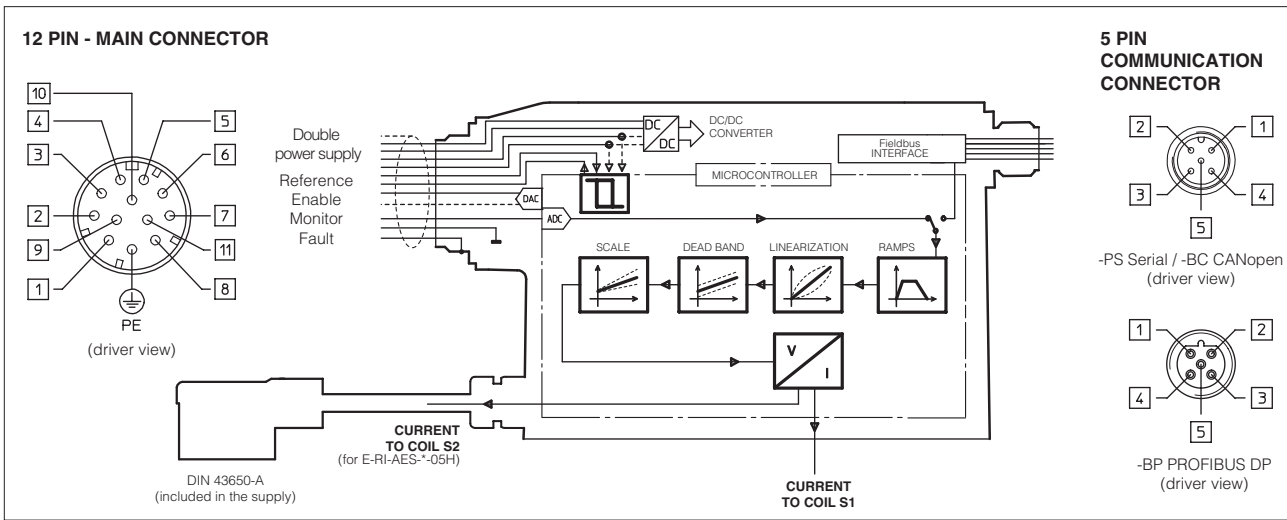

4 ELECTRONIC CONNECTIONS - 7 & 12 PIN MAIN CONNECTOR

Standard 7pin	/Z option 12pin	SIGNAL	TECHNICAL SPECIFICATIONS	NOTES
A	1	V+	Power supply 24 V _{DC} for solenoid power stage (see 6.1)	Input - power supply
B	2	V0	Power supply 0 V _{DC} for solenoid power stage (see 6.1)	Gnd - power supply
-	3	ENABLE	Enable (24 V _{DC}) or disable (0 V _{DC}) the driver (see 6.5)	Input - on/off signal
D	4	INPUT+	Reference analog input: ±10 V _{DC} maximum range (4 ÷ 20 mA for /I option) - see 6.2 differential INPUT+ and INPUT- (for 7 pin standard execution) common mode INPUT+ referred to AGND (for 12 pin /Z option)	Input - analog signal
E	-	INPUT -		
C	5	AGND	Ground : signal zero for MONITOR signal (pin F of 7 pin standard or pin 6 of /Z option) signal zero for INPUT+ signal (pin 4 of /Z option)	Gnd - analog signal
F	6	MONITOR	Monitor analog output: ±10 V _{DC} maximum range (see 6.3)	Output - analog signal
-	7	NC	do not connect	
-	8	NC	do not connect	
-	9	VL+	Power supply 24 V _{DC} for driver's logic (see 6.4)	Input - power supply
-	10	VL0	Power supply 0 V _{DC} for driver's logic (see 6.4)	Gnd - power supply
-	11	FAULT	Driver status : Fault (0V _{DC}) or normal working (24 V _{DC}) (see 6.6)	Output - on/off signal
G	PE	EARTH	Internally connected to driver housing	

Note: A minimum time of 270 to 340 ms have to be considered between the driver energizing with the 24 V_{DC} power supply and when the valve is ready to operate. During this time the current to the valve coils is switched to zero.

5 ELECTRONIC CONNECTIONS - 5 PIN COMMUNICATION M12 CONNECTOR

PIN	-PS Serial		-BC CANopen		-BP PROFIBUS DP	
	SIGNAL	TECHNICAL SPECIFICATION	SIGNAL	TECHNICAL SPECIFICATION	SIGNAL	TECHNICAL SPECIFICATION
1	NC	do not connect	CAN_SHLD	Shield	+5V	for termination
2	NC	do not connect	NC	do not connect	LINE-A	Bus line (high)
3	RS_GND	Signal zero data line	CAN_GND	Signal zero data line	DGND	data line and termination Signal zero
4	RS_RX	Valves receiving data line	CAN_H	Bus line (high)	LINE-B	Bus line (low)
5	RS_TX	Valves transmitting data line	CAN_L	Bus line (low)	SHIELD	

6 SIGNALS SPECIFICATIONS

Atos proportional valves are CE marked according to the applicable directives (e.g. Immunity/Emission EMC Directive and Low Voltage Directive). Installation, wirings and start-up procedures must be performed according to the general prescriptions shown in table F003 and in the user manuals included in the E-SW programming software.

The electrical signals of the valve (e.g. monitor signals) must not be directly used to activate safety functions, like to switch-ON/OFF the machine's safety components, as prescribed by the European standards (Safety requirements of fluid technology systems and components-hydraulics, EN-892)

6.1 Power supply and wirings (pin A,B / pin 1,2)

The power supply must be appropriately stabilized or rectified and filtered: apply at least a 10000 µF/40 V capacitance to single phase rectifiers or a 4700 µF/40 V capacitance to three phase rectifiers.

A safety fuse is required in series to each driver power supply: 2,5 A fuse

6.2 Reference Input Signal (pin D,E / pin 4,5)

The driver controls in closed loop the current to the valve proportionally to the external reference signal input.

The driver is designed to receive one analog reference input (pin D,E differential mode input).

The input range and polarity are software selectable within the ±10 V_{DC} maximum range; default settings are 0 ÷ +10 V_{DC} for two position and pressure single solenoid valves and ±10 V_{DC} for double solenoid valves and three position single solenoid valves (see valve's tech. table).

Driver with fieldbus interface (-BC or -BP) can be software set to receive reference value directly by the machine control unit (fieldbus master); in this case the analog reference input signal can be used for start-up and maintenance operations

Option /I

The maximum range of reference input signal is software selectable among 4 ÷ 20 mA (default with cable break detection), ±10mA, ±20mA or 0 ÷ 20mA

Option /Z

The reference input is available in common mode (pin 4 referred to pin 5) instead of the standard differential mode

6.3 Monitor Output Signal (pin F,C / pin 6,5)

The driver generates an analog output signal proportional to the actual valve's coil current (pin F/6 referred to pin C/5); the monitor output signal can be software set to show other signals available in the driver (e.g. analog reference, fieldbus reference).

The output maximum range is $\pm 10 \text{ Vdc}$: $0 \div +10 \text{ Vdc}$ for two position and pressure single solenoid valves and $\pm 10 \text{ Vdc}$ for double solenoid valves and three position single solenoid valves (see valve's tech. table).

Option /I

The maximum range of monitor output signal is software selectable within $\pm 10 \text{ Vdc}$ as standard version

6.4 Logic power supply (pin 9,10 - only for /Z option)

Option /Z provides separate power supply for the solenoid (pin 1,2) and for the digital electronic circuits (pin 9,10).

Cutting solenoid power supply allows to interrupt the valve functioning but keeping energized the digital electronics thus avoiding fault conditions of the machine fieldbus controller (e.g. for emergency, as provided by the European Norms EN954-1 for components with safety class 2).

Note: pin 2 and 10 (zero Volt) are connected together inside the electronics; see 6.1 for power supplies requirements

6.5 Enable Input Signal (pin 3,2 - only for /Z option)

To enable the driver, supply a 24Vdc on pin 3 referred to pin 2: when the Enable signal is set to zero the valve functioning is disabled (zero current to the solenoid) but the driver current output stage is still active. This condition does not comply with European Norms EN954-1

6.6 Fault Output Signal (pin 11,2 - only for /Z option)

Fault output signal indicates fault conditions of the driver (solenoid short circuits/not connected, reference signal cable broken for $4 \div 20\text{mA}$ input, etc.). Fault presence corresponds to 0 Vdc , normal working corresponds to 24 Vdc (pin 11 referred to pin2).

Fault status is not affected by the Enable input signal

7 SOFTWARE TOOLS

The driver configuration and parameters can be easily set with the Atos E-SW programming software, available in three different versions according to the driver's communication interfacing: E-SW-PS (Serial), E-SW-BC (CANopen) and E-SW-BP (PROFIBUS DP).

A proper connection is required between the PC and the electronic driver communication port: for a more detailed description of software interface, PC requirements, adapters, cables and terminators, please refer to technical table G500.

Proportional valves with fieldbus communication interface (-BC and -BP) can be directly managed by the machine control unit; it is required to implement in the machine control the standard communication as described in the user manuals supplied with the relevant programming software.

Programming software, must be ordered separately :

E-SW-* (mandatory - first supply) = Dvd including E-SW-* software installer, operator manuals, registration form for Atos digitals service

E-SW-*-N (optional - next supplies) = as above but not including the registration form for Atos digitals service

USB Adapters, Cables and Terminators, can be ordered separately (see tab. G500)

8 MAIN SOFTWARE PARAMETER SETTINGS

For a detailed descriptions of the available settings, wirings and installation procedures, please refer to the programming manuals included in the E-SW programming software (see [7]).

8.1 Scale

Scale function allows to set the maximum current supplied to the solenoid, corresponding to the max valve regulation, at maximum reference signal value.

This regulation allows to adapt the maximum current supplied from the driver to the specific nominal current of the proportional valves to which the driver is coupled; it is also useful to reduce the maximum valve regulation in front of maximum reference signal.

Two different Scale regulations are available for double solenoid valves: ScaleA for positive reference signal and ScaleB for negative reference signal

8.2 Bias and Threshold

Proportional valves may be provided with a dead band in the hydraulic regulation corresponding to their switch-off status.

This dead band discontinuity in the valve's regulation can be compensated by activating the Bias function, which adds a fixed preset Bias value to the reference signal (analog or fieldbus external input).

The Bias function is activated when the reference signal overcome the Threshold value, preset into the driver.

The Bias setting allows to calibrate the Bias current to the specific proportional valve to which the driver is coupled.

The Threshold setting is useful to avoid undesired valve regulation at zero reference signal when electric noise is present on the analog input signal: smaller threshold reduces the reference signal dead band, greater values are less affected by electric noise presence.

If fieldbus reference signal is active (see 6.2), threshold should be set to 0.

Two different Bias regulations are available for double solenoid valves or three position single solenoid valves: positive reference signals activate BiasA and negative reference signals activate BiasB.

Refer to the programming manuals for a detailed description of other software selectable Bias functions

8.3 Offset

Proportional valves may be provided with zero overlapping in the hydraulic regulation corresponding to zero reference input signal (valve's central spool position).

The Offset function allows to calibrate the Offset current, required to obtain valve's spool central position, to the specific hydraulic system setup (e.g. valve applied to cylinder with differential areas)

8.4 Ramps

The ramp generator allows to convert sudden change of electronic reference signal into smooth time-dependent increasing/decreasing of the current supplied to the solenoid.

Different ramp mode can be set:

- single ramp for any reference variation
- two ramps for increasing and for decreasing reference variations
- four ramps for positive/negative signal values and increasing/decreasing reference variations

Ramp generator is useful for application where smooth hydraulic actuation is necessary to avoid machine vibration and shocks.

If the proportional valve is driven by a closed loop controller, the ramps can lead to unstable behaviour, for these applications ramp function can be software disabled (default setting)

8.5 Linearization

Linearization function allows to set the relation between the reference input signal and the controlled valve's regulation.

Linearization is useful for applications where it is required to linearize the valve's regulation in a defined working condition

8.6 Dither

The dither is a high frequency modulation of the current supplied to the solenoid, to reduce the hysteresis of the valve's regulation: a small vibration in the valve's regulating parts considerably reduces static friction effects.

Dither frequency can be set in a range from 130 to 488 Hz (default value is 195Hz).

Lower dither setting reduces the hysteresis but also reduces the regulation stability. In some application this can lead to vibration and noise: right setting usually depends on system setup.

Default dither is a valid setting for a wide range of hydraulic applications

8.1, 8.2 - Scale, Bias & Threshold

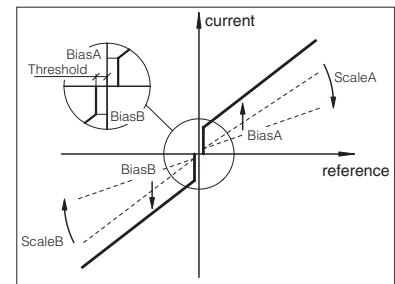

8.3 - Offset

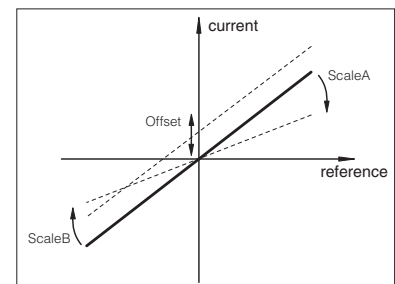

8.4 - Ramps

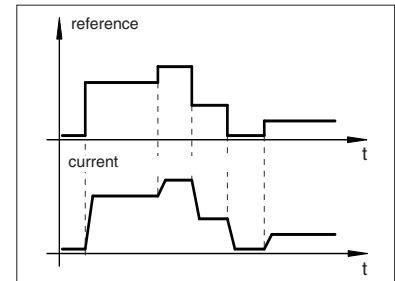

8.5 - Linearization

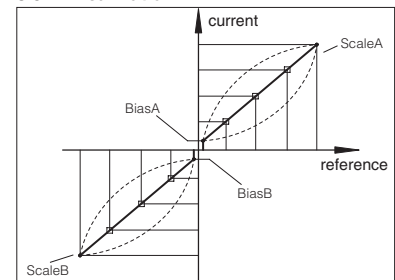

9 DRIVER CHARACTERISTICS

Power supply (see 6.1, 6.4)	Nominal: +24 Vdc Rectified and filtered: $V_{rms} = 21 \div 32 V_{MAX}$ (ripple max 10 % V_{PP})		
Max power consumption	50 W		
Reference input signal (see 6.2)	Input impedance: voltage $R_i > 50 \text{ k}\Omega$ (range $\pm 10 \text{ Vdc}$) current $R_i = 316 \Omega$ (range $4 \div 20 \text{ mA}$)		
Monitor output (see 6.3)	Output range : $\pm 10 \text{ Vdc}$ @ max 5mA		
Enable input (see 6.5)	Input impedance: $R_i > 10 \text{ k}\Omega$; range : $0 \div 5 \text{ Vdc}$ (ON state), $9 \div 24 \text{ Vdc}$ (OFF state), $5 \div 9 \text{ Vdc}$ (not accepted)		
Fault output (see 6.6)	Output range : $0 \div +24 \text{ Vdc}$ (ON state > power supply-2V ; OFF state < 1V) @ max 50mA		
Alarms	Solenoid coil not connected/short circuit, cable break with current reference signal, overtemperature, under temperature		
Format	Sealed box on the valve; IP67 protection degree		
Operating temperature	$-20 \div 60 \text{ }^\circ\text{C}$ (storage $-20 \div 70 \text{ }^\circ\text{C}$)		
Mass	approx. 385g		
Additional characteristics	Short circuit protection of solenoid's current supply; current control by P.I.D. with rapid solenoid switching		
Electromagnetic compatibility (EMC)	Immunity: EN 50082-2; Emission: EN 50081-2		
Communication interface Physical Layer Protocol	-PS Serial	-BC CANopen - see tab. G510	-BP PROFIBUS - see tab. G510
	serial RS232C Atos ASCII coding	optical insulated CAN ISO11898 CANopen EN50325-4 + DS408	optical insulated RS485 PROFIBUS DP EN50170-2/IEC61158
Recommended wiring cable	LiYCY shielded cables: $0,5 \text{ mm}^2$ for length up to 40m [$1,5 \text{ mm}^2$ for power supply and solenoid]		

10 MAIN CONNECTOR CHARACTERISTICS (to be ordered separately)

CODE	SP-ZH-7P	SP-ZM-7P	SP-ZH-12P
Type	Female straight circular socket plug 7pin	Female straight circular socket plug 7pin	Female straight circular socket plug 12pin
Standard	DIN 43563-BF6-3-PG11	According to MIL-C-5015 G	DIN 43651
Material	Plastic reinforced with fiber glass	Aluminium alloy with cadmiun plating	Plastic reinforced with fiber glass
Cable gland	PG11	PG11	PG16
Cable	LiYCY 7x 0,75 mm ² max 20 m 7 x 1 mm ² max 40 m	LiYCY 7x 0,75 mm ² max 20 m 7 x 1 mm ² max 40 m	LiCY 10 x 0,14 mm ² (signal) LiYY 3 x 1 mm ² (alimentation)
Connection type	to solder	to solder	to crimp
Protection (DIN 40050)	IP 67	IP 67	IP 65

11 COMMUNICATION CONNECTOR CHARACTERISTICS (to be ordered separately)

CODE	-PS Serial Connector	-BC CANopen Connector	-BP PROFIBUS DP Connector
	SP-ZH-5P	SP-ZH-5P	SP-ZH-5P/BP
Type	Female straight circular socket plug 5 pin	Female straight circular socket plug 5 pin	Male straight circular socket plug 5 pin
Standard	M12 – IEC 60947-5-2	M12 – IEC 60947-5-2	M12 – IEC 60947-5-2
Material	Plastic	Plastic	Plastic
Cable gland	PG9	PG9	PG9
Cable	LiYCY 5x0,25 mm ² shielded	CANBus Standard (301 DSP)	PROFIBUS DP Standard
Connection type	screw terminal	screw terminal	screw terminal
Protection (DIN 40050)	IP 67	IP 67	IP 67

12 OVERALL DIMENSIONS [mm]

