

Proportional throttle cartridges type **LIQZO-L***, 3-way

high dynamics, with two position transducers, sizes from 25 to 80

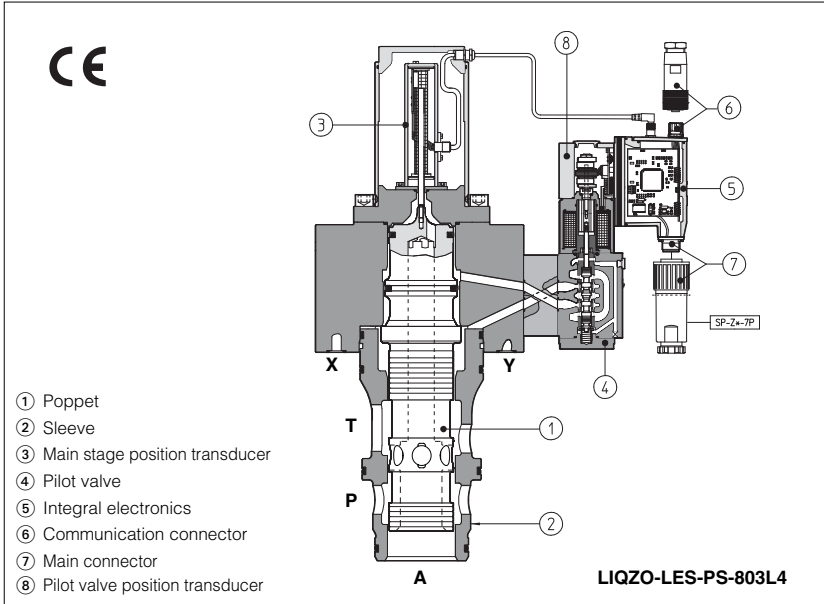

- ① Poppet
- ② Sleeve
- ③ Main stage position transducer
- ④ Pilot valve
- ⑤ Integral electronics
- ⑥ Communication connector
- ⑦ Main connector
- ⑧ Pilot valve position transducer

LIQZO-L* are 3-way proportional cartridge valves, with double position transducer which provide both directional and non compensated flow control according to electronic reference signal.

They operate in association with electronic drivers, see section 2, which supply the proportional valves with proper current to align valve regulation to the reference signal supplied to the electronic driver.

They are available in different executions:

- -L, with two integral position transducers ③, ⑧;
- -LE, -LES as -L plus analogue (LE) or digital (LES) integral electronics ⑤.

The regulation is operated by means of a spool ① with double piloting area sliding into a sleeve ② and provided of integral LVDT position transducer ③.

The spool is operated by means of a high performances proportional directional valve ④ in "rugged" executions to withstand high vibrations and mechanical stresses (type DLHZO for cartridge dimensions up to size 50 and type DLK-ZOR for cartridge dimensions up to size 80) - see tab. F180, provided of high precision sleeve and LVDT position transducer ⑧ for maximum regulating accuracy and dynamic response. It is controlled in double closed loop position by means of the LVDT position transducers ③ and ⑧.

The integral electronics ⑤ ensures factory presetting, fine functionality plus valve-to-valve interchangeability and simplified wiring and installation.

Standard 7 pin main connector is used for power supply, analog input reference and monitor signals.

12 pin connector is used for options /Z and /S*.

The special /S* options add a closed loop control of pressure (/SP) or force (/SF and /SL) to the basic closed loop spool position one.

Following communication interfaces ⑦ are available for the digital -LES execution:

- -PS, Serial communication interface. The valve reference signal is provided with analogue commands
- -BC, CANopen interface
- -BP, PROFIBUS DP interface

The valves with -BC and -BP interfaces can be integrated into a fieldbus communication network and thus digitally operated by the machine control unit.

Typical applications: plastic injection and blow moulding, ceramics, punching & nibbling machines, die-casting, foundry and sheet machinery;

Mounting surface: ISO 7368

Sizes from 25 to 80

Max flow up to 2100 l/min with differential pressure $\Delta p = 5$ bar, see section 2;

Max pressure = 350 bar.

1 MODEL CODE

	LIQZO	-	LES	-	PS	-	25		3		L4	/	*		**		/*
Flow control valve L = with two position integral transducers LE = as L plus integral electronics LES = as L plus integral digital electronics																Synthetic fluids: WG = water-glycol PE = phosphate ester	
Communication interfaces (only for LES) PS = RS232 serial BC = CANbus BP = PROFIBUS-DP																Series number	
Valve size, see section 3 25 32 40 50 63 80																Electronic options for -LE execution see section 6: F = fault signal I = current reference input and monitor (4÷20 mA) Q = enable signal Z = enable, fault and monitor signal	
Valve configuration, see section 3 3 = 3 way																Electronic options for -LES execution see section 6: I = current reference input and monitor (4÷20 mA) Z = double power supply, enable, fault and monitor	
Spool type (regulating characteristics): L4 = linear																Special options for -LES execution see section 6: SF = additional closed loop force control, with two remote pressure transducers SL = additional closed loop force control with one remote load cell SP = additional closed loop pressure control with one remote pressure transducer C = current feedback interface for transducer(s) only for options /SF, /SL, /SP	

8 ELECTRONIC DRIVERS FOR LIQZO-L*

Valve model	-L	-LE	-LES
Drivers model	E-ME-L	E-RI-LE	E-RI-LES
Data sheet	G150	G200	G210

Note: For power supply and communication connector see section 14

2 HYDRAULIC CHARACTERISTICS (based on mineral oil ISO VG 46 at 50 °C) (3)

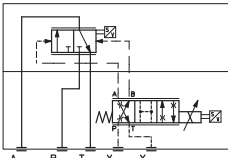
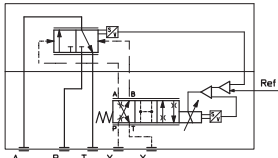
Hydraulic symbols						
Model	LIQZO-L*					
Size	25	32	40	50	63	80
Max regulated flow at $\Delta p = 5$ bar at $\Delta p = 10$ bar Maximum flow	[l/min] 185 260 500	330 470 850	420 590 1050	780 1100 2000	1250 1750 3100	2100 3000 5000
Max pressure	350					
Nominal flow of pilot valve at $\Delta p = 70$ bar	4	7	28	40	40	40
Leakage of pilot valve at $P = 100$ bar	0,2	0,2	0,5	0,7	0,7	0,7
Response time $\pm 100\%$ step signal (1)	22	25	27	28	30	31
Pilot volume (2)	2,16	7,2	8,9	17,7	33,8	42,7
Hysteresis	$\leq 0,1\%$					
Repeatability	$\pm 0,1\%$					
Thermal drift	zero point displacement $< 1\%$ at $\Delta T = 40^\circ\text{C}$					

Note:

Above performance data refer to valves coupled with Atos electronic drivers, see section 2.

- Recommended piloting pressure is 140 ± 160 bar.
- In case of long time shutdown of the hydraulic supply to the pilot valve, the driver has to be switched off to avoid its overheating.

4 GENERAL NOTES

LIQZO-L* proportional cartridges are CE marked according to the applicable Directives (e.g. Immunity/Emission EMC Directive and Low Voltage Directive).

Installation, wirings and start-up procedures must be performed according to the general prescriptions shown in table F003 and in the installation notes supplied with relevant components.

The electrical signals of the valve (e.g. monitor signals) must not be directly used to activate safety functions, like to switch-ON/OFF the machine's safety components, as prescribed by the European standards (Safety requirements of fluid technology systems and components-hydraulics, EN-892).

5 CONNECTIONS FOR -L EXECUTION

SOLENOID POWER SUPPLY CONNECTOR	
PIN	Signal description
1	SUPPLY
2	SUPPLY
3	GND

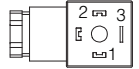

PILOT VALVE POSITION TRANSDUCER CONNECTOR	
PIN	Signal description
1	OUTPUT SIGNAL
2	SUPPLY -15 V _{DC}
3	SUPPLY +15 V _{DC}
4	GND

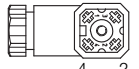

MAIN STAGE POSITION TRANSDUCER CONNECTOR			
SIZES 16 + 40		SIZE 50 + 80	
PIN	Signal description	PIN	Signal description
1	OUTPUT SIGNAL	1	OUTPUT SIGNAL
2	SUPPLY -15 V _{DC}	2	NOT CONNECTED
3	SUPPLY +15 V _{DC}	3	SUPPLY +24 V _{DC}
4	GND	4	GND

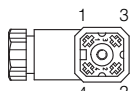

6 ANALOG INTEGRAL DRIVERS -LE - OPTIONS

Standard driver execution provides on the 7 pin main connector:

Power supply - 24V_{DC} must be appropriately stabilized or rectified and filtered; a 2,5 A safety fuse is required in series to the driver power supply. Apply at least a 10000 $\mu\text{F}/40$ V capacitance to single phase rectifiers or a 4700 $\mu\text{F}/40$ V capacitance to three phase rectifiers

Reference input signal - analogue differential input with ± 10 V_{DC} nominal range (pin D,E), proportional to desired valve spool position

Monitor output signal - analog output signal proportional to the actual valve's spool position with ± 10 V_{DC} nominal range

Following options are available to adapt standard execution to special application requirements:

6.1 Option /F

It provides a Fault output signal in place of the Monitor output signal, to indicate fault conditions of the driver (cable interruption of spool transducers or reference signal - for /I option): Fault presence corresponds to 0 V_{DC}, normal working corresponds to 24 V_{DC}.

6.2 Option /I

It provides the 4÷20 mA current reference and monitor signals instead of the standard ± 10 V_{DC}

It is normally used in case of long distance between the machine control unit and the valve or where the reference signal can be affected by electrical noise; the valve functioning is disabled in case of reference signal cable breakage.

6.3 Option /Q

It provides the possibility to enable or disable the valve functioning without cutting the power supply (the valve functioning is disabled but the driver current output stage is still active). To enable the driver supply a 24V_{DC} on the enable input signal.

6.4 Option /Z

This option includes /F and /Q features, plus the Monitor output signal.

When the driver is disabled (0 V_{DC} on Enable signal) Fault output is forced to 0 V_{DC}.

6.5 Possible combined options: /FI and /IZ

7 ANALOG INTEGRAL DRIVERS -LE - MAIN FUNCTIONS AND ELECTRONIC CONNECTIONS

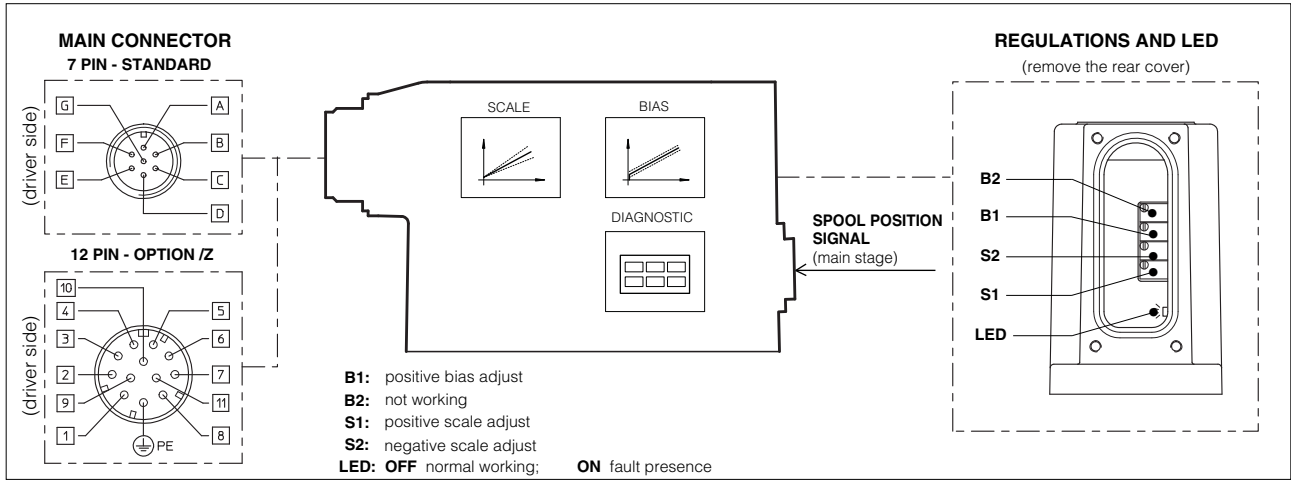

7.1 ELECTRONIC CONNECTIONS - 7 & 12 PIN MAIN CONNECTORS

Standard 7pin	/Z option 12pin	SIGNAL	TECHNICAL SPECIFICATIONS	NOTES
A	1	V+	Power supply 24 Vdc for solenoid power stage and driver logic	Input - power supply
B	2	V0	Power supply 0 Vdc for solenoid power stage and driver logic	Gnd - power supply
C (1)	7	AGND	Ground - signal zero for MONITOR signal (for standard, /Z option)	Gnd - analog signal
	3	ENABLE	Enable (24 Vdc) or disable (0 Vdc) the driver (for /Q and /Z options)	Input - on/off signal
D	4	INPUT+	Reference analog differential input: ±10 Vdc maximum range (4 ÷ 20 mA for /I option)	Input - analog signal
E	5	INPUT -		
F (2)	6	MONITOR	Monitor analog output: ±10 Vdc maximum range (4 ÷ 20 mA for /I option)	Output - analog signal
	11	FAULT	Fault (0V) or normal working (24V) (for /F and /Z option)	Output - on/off signal
-	8	R_ENABLE	Repeat Enable - output repetition of Enable input	Output - on/off signal
-	9	NC	do not connect	Output - on/off signal
-	10	NC	do not connect	Output - on/off signal
G	PE	EARTH	Internally connected to the driver housing	

Notes:

(1) with /Q option ENABLE signal replaces AGND on pin C; MONITOR signal is referred to pin B
(2) with /F option FAULT signal replaces MONITOR on pin F.

- A minimum time of 50ms to 100ms have be considered between the driver energizing with the 24 Vdc power supply and when the valve is ready to operate. During this time the current to the valve coils is switched to zero.

9 DIGITAL INTEGRAL DRIVERS -LES - OPTIONS

Standard driver execution provides on the 7 pin main connector:

- Power supply** - 24Vdc must be appropriately stabilized or rectified and filtered; a 2,5 A safety fuse is required in series to each driver power supply. Apply at least a 10000 µF/40 V capacitance to single phase rectifiers or a 4700 µF/40 V capacitance to three phase rectifiers
- Reference input signal** - analogue differential input with ±10Vdc nominal range (pin D,E), proportional to desired valve spool position
- Monitor output signal** - analog output signal proportional to the actual valve's spool position with ±10Vdc nominal range

Following options are available to adapt standard execution to special application requirements:

9.1 Option /I

It provides 4÷20 mA current reference and monitor signals instead of the standard ±10 V. It is normally used in case of long distance between the machine control unit and the valve or where the reference signal can be affected by electrical noise; the valve functioning is disabled in case of reference signal cable breakage.

9.2 Option /Z

It provides on a 12 pin main connector the above standard features plus:

Logic power supply

Option /Z provides separate power supply for the solenoid (pin 1, 2) and for the digital electronic circuits (pin 9, 10). Cutting solenoid power supply allows to interrupt the valve functioning but keeping energized the digital electronics thus avoiding fault conditions of the machine fieldbus controller (e.g. for emergency, as provided by the European Norms EN954-1 for components with safety class 2).

Enable Input Signal

To enable the driver, supply a 24Vdc on pin 3 referred to pin 2: when the Enable signal is set to zero the valve functioning is disabled (zero current to the solenoid) but the driver current output stage is still active, this condition does not comply with European Norms EN954-1.

Fault Output Signal

Fault output signal indicates fault conditions of the driver (solenoid short circuits/not connected, reference signal cable broken for 4÷20mA input, etc.). Fault presence corresponds to 0 Vdc, normal working corresponds to 24Vdc (pin 11 referred to pin 2): Fault status is not affected by the Enable input signal

9.3 Options /SP, /SF and /SL

These options add the closed loop control of pressure (/SP) or force (/SF and /SL) to the basic functions of proportional directional valves: a dedicated software alternates pressure (force) and valve's spool position controls depending on the actual hydraulic system conditions. A dedicated connector is available for the additional transducers that are required to be interfaced to the valve's driver (1 pressure transducer for /SP, 2 pressure transducers for /SF or 1 load cell for /SL). Main 12 pin connector is the same as /Z option plus two analog signals specific for the pressure (force) control: one for reference (pin 7) and one for monitor (pin 8). For further details please refer to the driver technical table **G210, section 13**.

9.4 Options /C

Options /CSP, /CSF and /CSL are available to connect pressure (force) transducers with 4 ÷ 20mA current output signal.

9.5 Possible combined options: /CSP, /CSF, /CSL, /CISP, /CISF, /CISL and /IZ

9 DIGITAL INTEGRAL DRIVERS -LES - MAIN FUNCTIONS AND ELECTRONIC CONNECTIONS

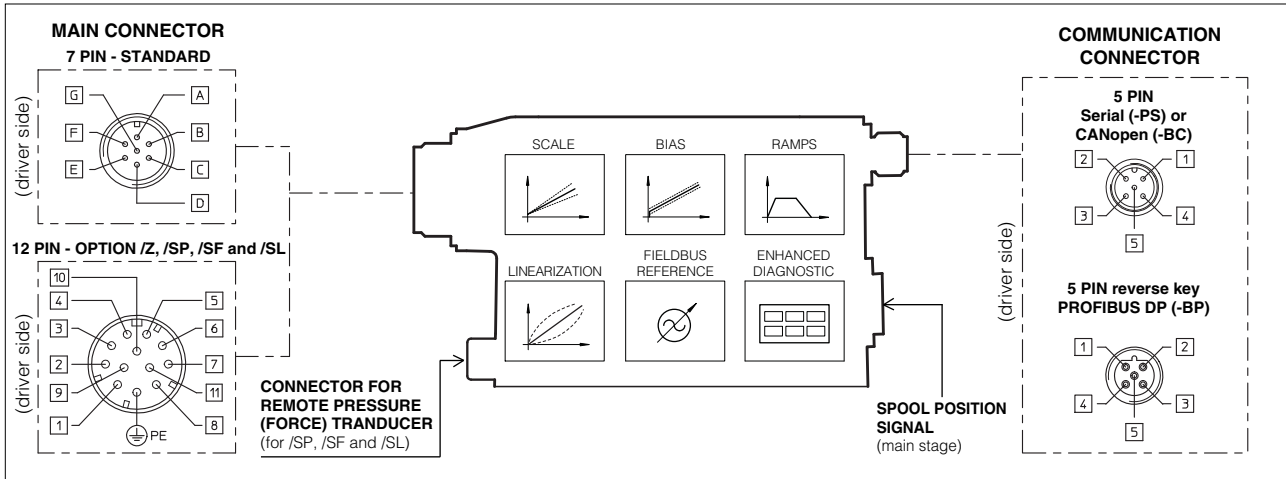

9.1 ELECTRONIC CONNECTIONS - 7 & 12 PIN MAIN CONNECTORS

Standard 7pin	/Z option 12pin	SIGNAL	TECHNICAL SPECIFICATIONS	NOTES
A	1	V+	Power supply 24 Vdc for solenoid power stage (and for driver logic on 7 pin connection)	Input - power supply
B	2	V0	Power supply 0 Vdc for solenoid power stage (and for driver logic on 7 pin connection)	Gnd - power supply
-	3	ENABLE	Enable (24 Vdc) or disable (0 Vdc) the driver	Input - on/off signal
D	4	INPUT+	Reference analog input: ± 10 Vdc maximum range (4 \div 20 mA for /I option)	Input - analog signal
E	-	INPUT -	standard: differential input; /Z option: common mode INPUT+ referred to AGND	
C	5	AGND	Ground - signal zero for MONITOR signal signal zero for INPUT+ signal (only for /Z option)	Gnd - analog signal
F	6	MONITOR	Monitor analog output: ± 10 Vdc maximum range (4 \div 20 mA for /I option)	Output - analog signal
-	7	NC	do not connect (pressure/force input for /SP, /SF and /SL options, see 8.3)	
-	8	NC	do not connect (pressure/force monitor for /SP, /SF and /SL options, see 8.3)	
-	9	VL+	Power supply 24 Vdc for driver logic	Input - power supply
-	10	VLO	Power supply 0 Vdc for driver logic	Gnd - power supply
-	11	FAULT	Fault (0V) or normal working (24V)	Output - on/off signal
G	PE	EARTH	Internally connected to the driver housing	

Note: A minimum time of 300 to 500 ms have be considered between the driver energizing with the 24 Vdc power supply and when the valve is ready to operate. During this time the current to the valve coils is switched to zero.

9.2 ELECTRONIC CONNECTIONS - 5 PIN COMMUNICATION CONNECTORS

PIN	-PS Serial		-BC CANopen		-BP PROFIBUS DP	
	SIGNAL	TECHNICAL SPECIFICATION	SIGNAL	TECHNICAL SPECIFICATION	SIGNAL	TECHNICAL SPECIFICATION
1	NC	do not connect	CAN_SHLD	Shield	+5V	for termination
2	NC	do not connect	NC	do not connect	LINE-A	Bus line (high)
3	RS_GND	Signal zero data line	CAN_GND	Signal zero data line	DGND	data line and termination Signal zero
4	RS_RX	Valves receiving data line	CAN_H	Bus line (high)	LINE-B	Bus line (low)
5	RS_TX	Valves transmitting data line	CAN_L	Bus line (low)	SHIELD	

10 SOFTWARE TOOLS

The functional parameters of the digital valves, as the bias, scale, ramp and linearization of the regulation characteristic, can be easily set and optimized with graphic interface by using the Atos E-SW software and the relevant USB adapters, cable and terminators, **see tab. G500**. Valves with fieldbus communication interface (-BC and -BP) can be completely managed by the machine control unit; it is required to implement in the machine control the standard communication as described in the user manuals supplied with the relevant programming software. For detailed description of available fieldbus features, **see tab. G510**

11 MAIN CHARACTERISTICS OF PROPORTIONAL DIRECTIONAL VALVES

Assembly position	Any position
Subplate surface finishing	Roughness index, \sqrt{Ra} flatness ratio 0,01/100 (ISO 1101)
Ambient temperature	-20°C \div +70°C for -L execution; -20°C \div +60°C for -LE and LES executions
Fluid	Hydraulic oil as per DIN 51524 ... 535 for other fluids see section I
Recommended viscosity	15 \div 100 mm ² /s at 40°C (ISO VG 15 \div 100)
Fluid contamination class	ISO 18/15 achieved with in line filters of 10 μ m and $\beta_{10} \geq 75$ (recommended)
Fluid temperature	-20°C +60°C (standard and /WG seals) -20°C +80°C (/PE seals)
Coil resistance R at 20°C	3 \div 3,3 Ω
Max. solenoid current	2,6 A
Max. power	35 Watt
Insulation class	H (180°) Due to the occuring surface temperatures of the solenoid coils, the European standards
Protection degree (CEI EN-60529)	ISO 13732-1 and EN982 must be taken into account IP65 for -L execution; IP65-67 for -LE and -LES executions, depending to the connector type (see sect. I4)
Duty factor	Continuous rating (ED=100%)

6 DIAGRAMS (based on mineral oil ISO VG 46 at 50 °C)

6.1 Regulation diagrams, see note

1 = LIQZO-L* (all sizes)

Hydraulic configuration vs. reference signal:

Reference signal 0 ÷ +10 V P → A
12 ÷ 20 mA

Reference signal 0 ÷ -10 V A → T
4 ÷ 12 mA

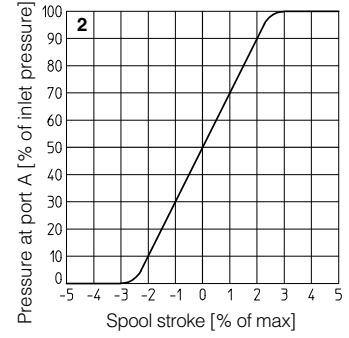
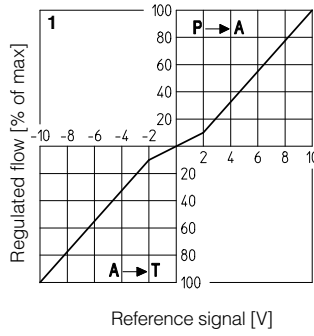

6.2 Pressure gain diagram

2 = LIQZO-L* (all sizes)

6.3 Bode diagrams

1 = LIQZO-L*-253L4: ± 90%

2 = LIQZO-L*-253L4: ± 5%

3 = LIQZO-L*-323L4: ± 90%

4 = LIQZO-L*-323L4: ± 5%

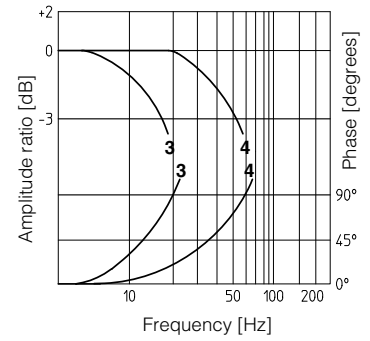
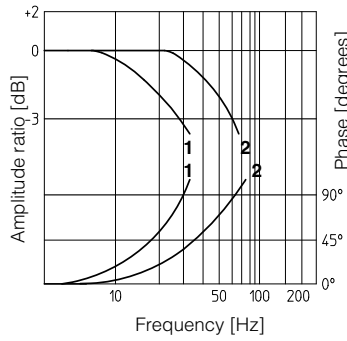

5 = LIQZO-L*-403L4: ± 90%

6 = LIQZO-L*-403L4: ± 5%

7 = LIQZO-L*-503L4: ± 90%

8 = LIQZO-L*-503L4: ± 5%

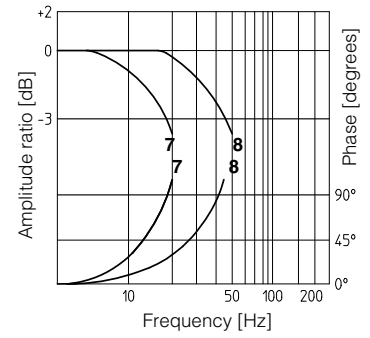
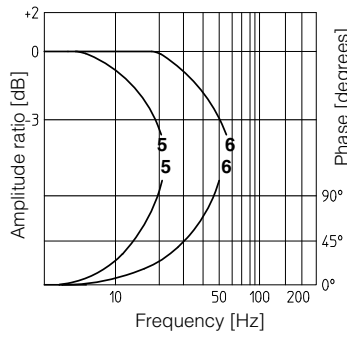

9 = LIQZO-L*-633L4: ± 90%

10 = LIQZO-L*-633L4: ± 5%

11 = LIQZO-L*-803L4: ± 90%

12 = LIQZO-L*-803L4: ± 5%

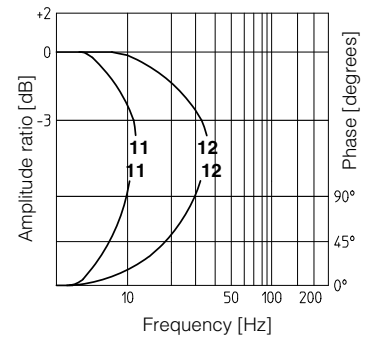
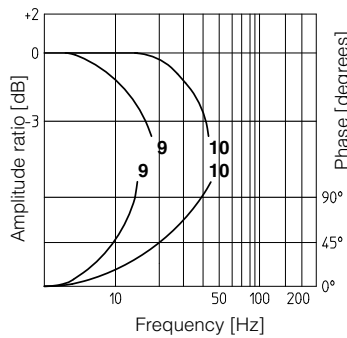

6.4 Dynamic response

The response times in section 2 and the frequency responses of the bode diagrams in sections 6.3, have to be considered as average values. For the valves with digital electronics the dynamics performances can be optimized by setting the internal software parameters.

7 INSTALLATION DIMENSIONS [mm]

Size 25, 32 and 40

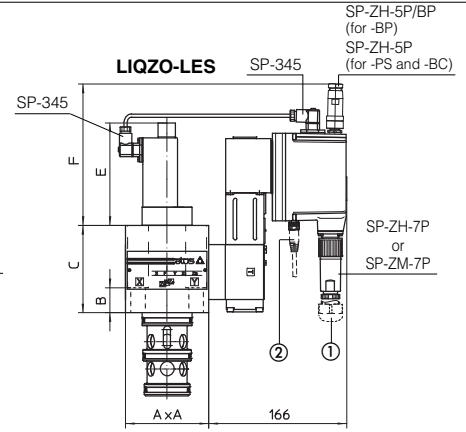
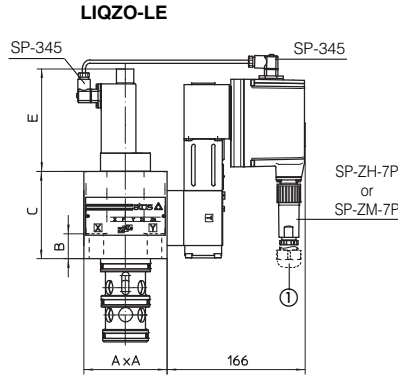
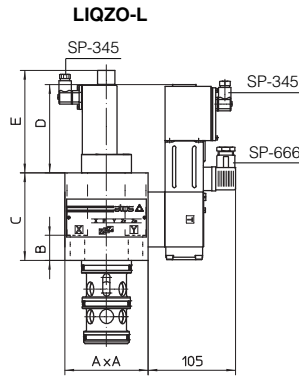

Size 50

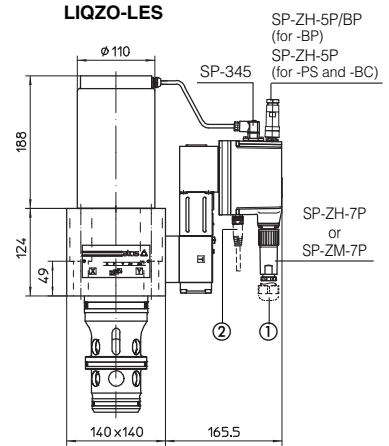
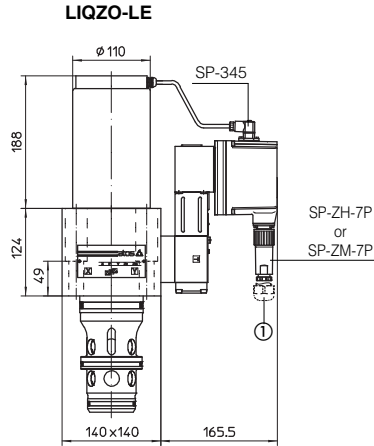
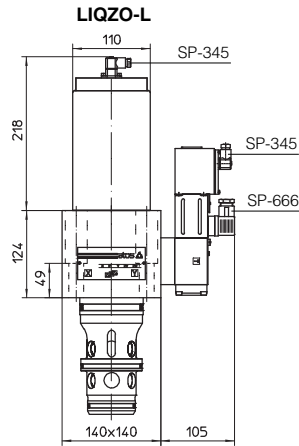

Size 63 and 80

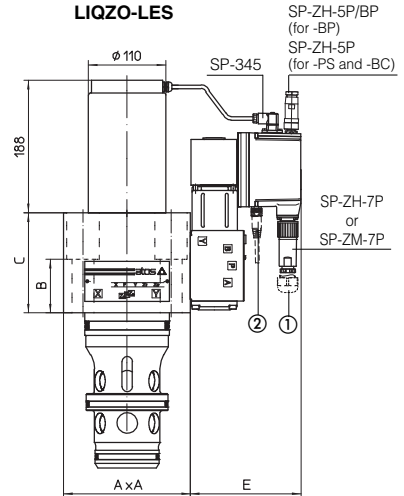
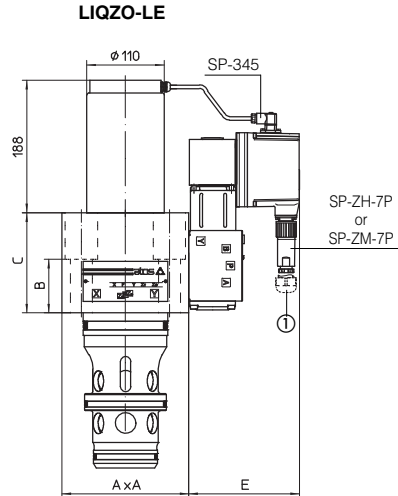
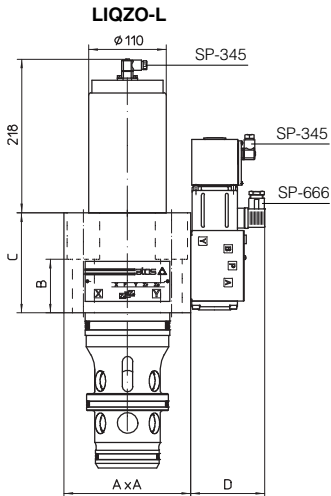

- ① Dotted line = 12 pin connector SP-ZH-12P for options /Z
- ② Dotted line = M8 connector SP-ZH-4P-M8/5 moulded on cable 5 mt lenght for pressure or force transducer (options /SL, /SP)
M8 connector SP-ZH-4P-M8/2-2 moulded with 2 cables, 2 mt lenght for 2 pressure transducers (options /SF)

Size	A	B	C	D	E	F	Fastening bolts class 12.9	Tightening torque	Weight (Kg)	
									L	LE-LES
25	85	80	95	117	83	-	N°4 M12x100	125 Nm	9,2	9,8
32	100	30	105	106	123	140	N°4 M16x60	300 Nm	11,9	12,6
40	125	39	120	95	123	128	N°4 M20x70	600 Nm	17,7	18,3
50	see drawing						N°4 M20x80	600 Nm	24,9	25,6
63	180	76	142	-	-	-	N°4 M30x120	2100 Nm	45	47,6
80	∅ 250	55	165	-	-	-	N°8 M24x80	1000 Nm	72,6	73,3

Mounting surface: ISO 7368
(see table P005)

14 MODEL CODES OF POWER SUPPLY AND COMMUNICATION CONNECTORS (to be ordered separately)

VALVE VERSION	-L		-LE, -LES		-LE/Z	LES -PS, -BC	LES -BP	LES /SF, /SL, /SP
	Power supply	Transducer						
CONNECTOR CODE	SP-666	SP-345	SP-ZH-7P	SP-ZM-7P	SP-ZH-12P	SP-ZH-5P	SP-ZH-5P/BP	SP-ZH-4P-M8* (1)
PROTECTION DEGREE	IP65	IP65	IP67	IP67	IP65	IP67	IP67	IP67
DATA SHEET	K500		G200, G210, K500			G210, K500		

- (1) M8 connector SP-ZH-4P-M8/5 moulded on cable 5 mt lenght for pressure or force transducer (options /SL, /SP)
M8 connector SP-ZH-4P-M8/2-2 moulded with 2 cables, 2 mt lenght for 2 pressure transducers (options /SF)

connectors supplied with the valve