

On-off active safety cartridges type LIDAS, 2-way

with optional mechanical microswitch or proximity sensor, ISO 7368 sizes from 16 to 50

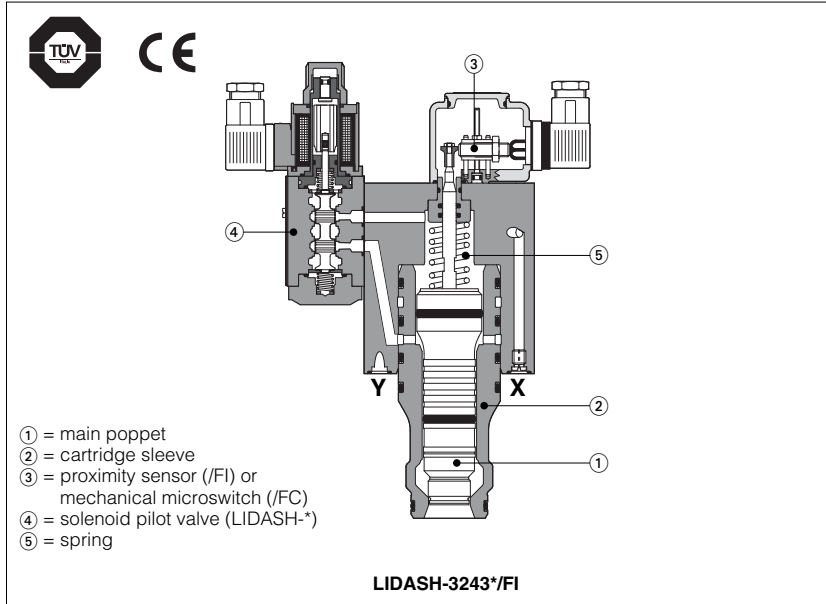

LIDAS are 2-way active cartridge valves, designed for mounting in manifold blocks and providing the leak-free shut-off function of the hydraulic line.

Configuration and construction:

The poppet ① is hydraulically active operated in both directions, ensuring in this way higher reliability and faster response time respect to the conventional spring cartridge valves.

The spring ⑤ ensures the valve closing in absence of pressure in the system.

They are available in different executions:

- without pilot solenoid valve
- with on-off pilot solenoid valve assembled on the cartridge
- with mechanical microswitch or inductive proximity sensor indicating the open/closed condition of the poppet, for safety applications to fulfill the safety criteria imposed by the European Machine Directive 98/37/CE.

Features:

- ISO 7368 sizes from 16 to 50
- Version /FI and /FC are CE marked and certified by TÜV according to EN982, EN201, EN422, EN693, EN12622
- typical applications: presses, injection moulding machines
- max flow up to 2000 l/min with $\Delta p = 5$ bar
- max pressure: 350 bar

1 MODEL CODE

LIDAS H - 40 43 3 / FI / NC - I X 24DC ** /*

On-off active cartridges, according to ISO 7368

Pilot control
 - = without pilot solenoid valve
 H = with pilot solenoid valve

Size: **16 25 32 40 50**

Poppet type: see section 2

31 } Not available for
33 } option /FC or /FI
43 (with dumping nose)

3 = spring cracking pressure 3 bar

Optional poppet sensor
FC = mechanical microswitch
FI = inductive proximity sensor

Synthetic fluids
WG = water glycol
PE = phosphate ester

Series number

Only for LIDASH
 Voltage code, see section 5

Only for LIDASH
X = without connector, see sec. 4

Pilot solenoid valve
I = DHU for AC and DC supply
U = DHU for DC supply

Electrical signalling, only for /FI version (1):
/NC = electric contact is closed when the valve is de-energized
/NO = electric contact is open when the valve is de-energized

(1) For /FC version both the normally open contact and the normally closed contact are already available on the connector

Cartridge areas

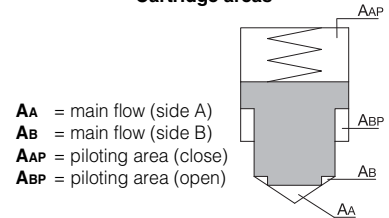

Thanks to the areas ratio $AAP/(AA+AB)$, see section 2, the valve closing is always ensured with a piloting pressure (X port) equal to the line pressure (A or B line).

2 HYDRAULIC CHARACTERISTICS (based on mineral oil ISO VG 46 at 50 °C)

Size	16	25	32	40	50
Max regulated flow at $\Delta p = 5$ bar	220	400	600	1300	2000
Maximum flow	550	1000	1400	2700	4000
Max pressure (ports A, B, X, Y)	350 (port Y = 2 bar for LIDASH)				
Poppet type	31	33, 43	31	31	33, 43
AA [cm ²]	2,27	1,43	4,91	3,46	8,04
AB (% of AA)	0	58,6	0	41,7	0
ABP (% of AA)	67,5	107,0	63,8	90,5	56,3
AAP (% of AA)	167,5	265,6	163,8	232,2	156,3
AA / (AA + AB) poppet ratio	1 for poppet 31		0,6 for poppet 33, 43		
AAP / (AA + AB) piloting ratio	1,6 for poppet 31		1,6 for poppet 33, 43		

3 MAIN CHARACTERISTICS OF CARTRIDGES VALVES TYPE LIDAS

Assembly position / location	Any position	
Subplate surface finishing	Roughness index $\sqrt{0.4}$ flatness ratio 0,01/100 (ISO 1101)	
Ambient temperature	from -20°C to +70°C	
Fluid	Hydraulic oil as per DIN 51524 535; for other fluids see section 1	
Recommended viscosity	15 ÷ 100 mm ² /s at 40°C (ISO VG 15 ÷ 100)	
Fluid contamination class	ISO 19/16, achieved with in line filters at 25 µm value and $\beta_{25} \geq 75$ (recommended)	
Fluid temperature	-20°C +60°C (standard and /WG seals) -20°C +80°C (/PE seals)	
Flow direction	B → A (preferred) or A → B	
Piloting	LIDAS	Pressure to X = close Pressure to Y = open
	LIDASH	De-energized = close Energized = open

3.1 Coils characteristics (only for LIDASH)

Insulation class	H (180°C) Due to the occurring surface temperatures of the solenoid coils, the European standards EN563 and EN982 must be taken into account
Connector protection degree	IP 65
Relative duty factor	100%
Supply voltage and frequency	See electric feature 5
Supply voltage tolerance	± 10%

4 ELECTRIC CONNECTORS ACCORDING TO DIN 43650 - the connectors must be ordered separately

Code of connector	Function
SP-666	Connector IP-65, suitable for direct connection to electric supply source
SP-667	As SP-666 connector IP-65 but with built-in signal led, suitable for direct connection to electric supply source.
SP-669	With built-in rectifier bridge for supplying DC coils by alternating current (AC 110V and 230V - I _{max} 1A).

For other available connectors, see tab. E010 and K500

5 ELECTRIC FEATURES (only for LIDASH)

Pilot valve	External supply nominal voltage ± 10%	Voltage code	Type of connector	Power consumption (2)	Code of spare coil of pilot solenoid valve		Colour of coil label			
					DHI	DHU				
DHI	6 DC	6 DC	SP-666 or SP-667	33 W	SP-COU-6DC / 80	SP-COU-6DC / 80	brown			
	9 DC	9 DC			-	-	light blue			
	12 DC	12 DC			SP-COU-12DC / 80	SP-COUR-12DC / 10	green			
	14 DC	14 DC			SP-COU-14DC / 80	SP-COUR-14DC / 10	brown			
	18 DC	18 DC			-	-	blue			
	24 DC	24 DC			SP-COU-24DC / 80	SP-COUR-24DC / 10	red			
	28 DC	28 DC			SP-COU-28DC / 80	SP-COUR-28DC / 10	silver			
	48 DC	48 DC			SP-COU-48DC / 80	-	silver			
	110 DC	110 DC			SP-COU-110DC / 80	SP-COUR-110DC / 10	gold			
	125 DC	125 DC			SP-COU-125DC / 80	-	blue			
	220 DC	220 DC			SP-COU-220DC / 80	SP-COUR-220DC / 10	black			
	DHU	24/50 AC			24/50/60 AC	SP-669	60 VA (3)	SP-COI-24/50/60AC / 80 (1)	-	pink
		48/50 AC			48/50/60 AC			SP-COI-48/50/60AC / 80 (1)	-	white
		110/50 AC			110/50/60 AC			SP-COI-110/50/60AC / 80 (1)	-	yellow
120/60 AC		120/60 AC	SP-COI-120/60AC / 80	-	white					
230/50 AC		230/50/60 AC	SP-COI-230/50/60AC / 80 (1)	-	light blue					
230/60 AC		230/60 AC	SP-COI-230/60AC / 80	-	silver					
110/50 AC		6 DC	SP-669	40 VA	SP-COU-110RC / 80			SP-COUR-110RC / 10	gold	
120/60 AC		12 DC			40 VA					
230/50 AC		110RC			40 VA					
230/60 AC		230RC			35 VA			SP-COU-230RC / 80	SP-COUR-230RC / 10	blue

- Coil can be supplied also with 60 Hz of voltage frequency: in this case the performances are reduced by 10 ÷ 15% and the power consumption is 55 VA.
- Average values based on tests performed at nominal hydraulic condition and ambient/coil temperature of 20°C.
- When solenoid is energized, the inrush current is approx 3 times the holding current. Inrush current values correspond to a power consumption of about 150 VA.

6 TECHNICAL CHARACTERISTICS OF INDUCTIVE PROXIMITY SENSORS AND MECHANICAL MICROSWITCHES

INDUCTIVE PROXIMITY SENSORS /FI		
Supply voltage [V]	10÷30	
Ripple max [%]	15	
Max current [mA]	200	
Power consumption [mA]	8	
Voltage drop [V]	3	
Max switching frequency [Hz]	1000	
Max peak pressure [bar]	350	
Mechanical life	virtually infinite	

MECHANICAL MICROSWITCHES /FC				
Max switching power	AC	125 V	5 A	5 A
		250 V	5 A	5 A
	DC	30 V	5 A	3 A
		50 V	1 A	1 A
		125 V	0,5 A	0,03 A
		250V	0,25 A	0,03 A
Mechanical life	Min 10 ⁷ cycles			

7 CONNECTING SCHEMES OF INDUCTIVE PROXIMITY SENSORS AND MECHANICAL MICROSWITCHES

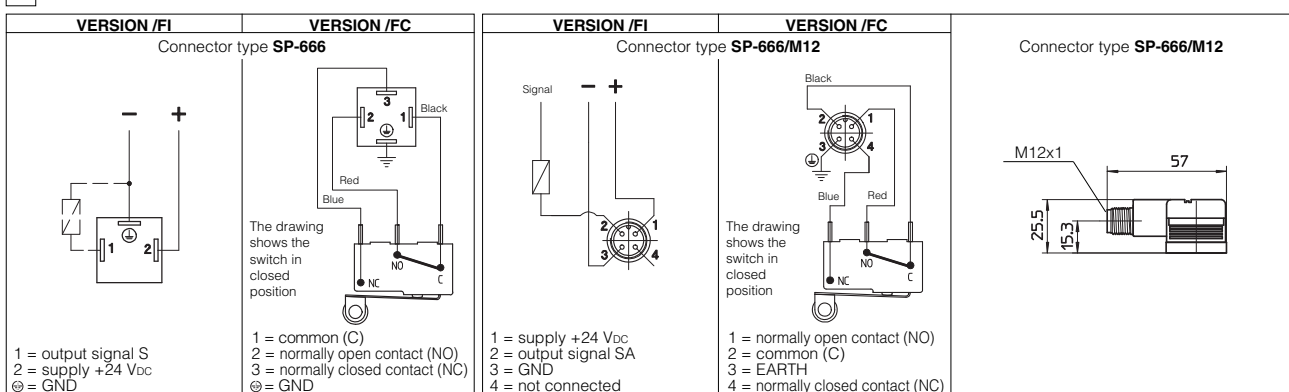

For the signal status see section 8

8 SIGNAL STATUS - LIDAS*/FI and LIDAS*/FC

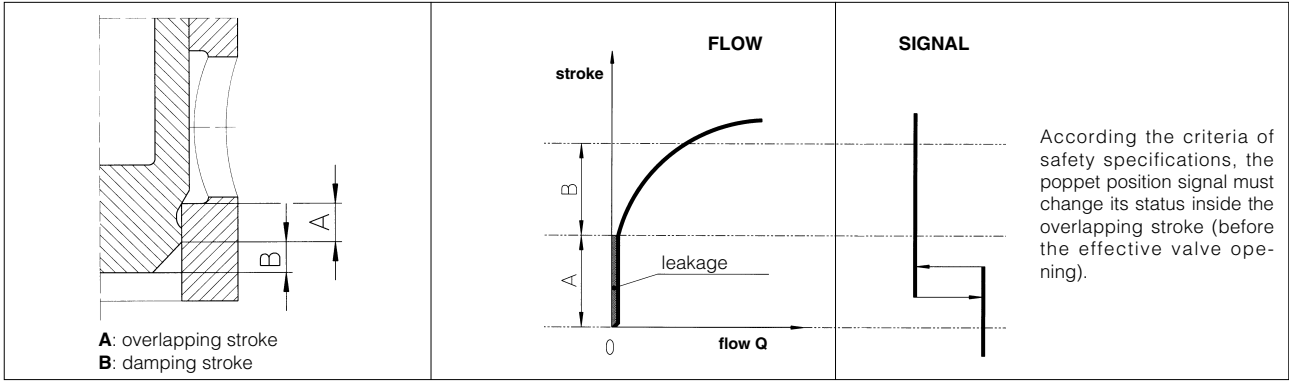

9 Q/Δp DIAGRAMS (based on mineral oil ISO VG 46 at 50 °C)

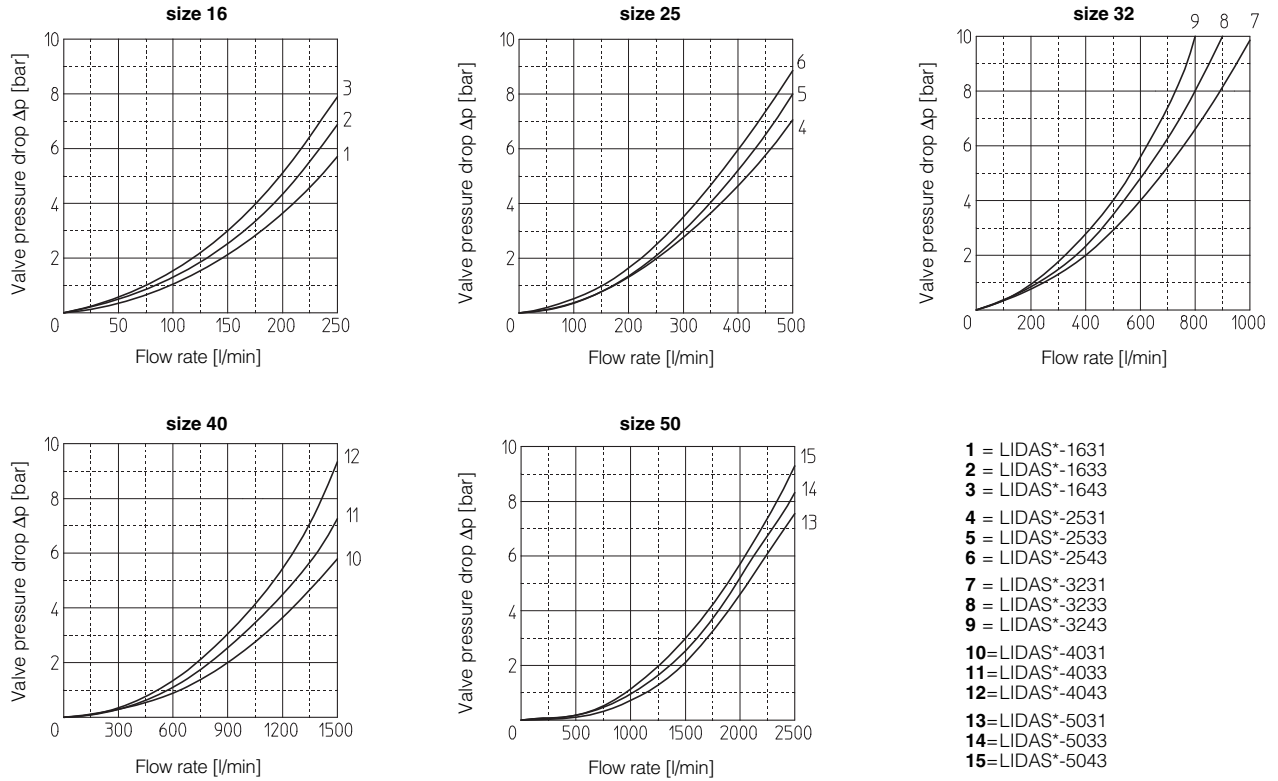

10 COVER INTERFACE AND RECESS DIMENSIONS [mm]

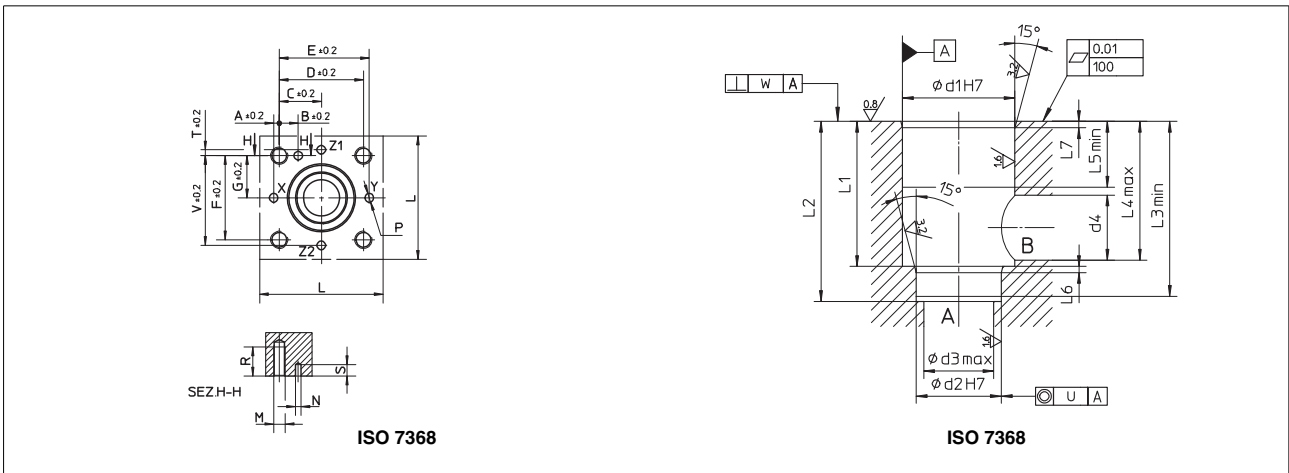

Size	COVER INTERFACE													RECESS												
	A	B	C	D	E	F	G	L	M	∅N	P _{max}	R	S _{min}	∅d1	∅d2	∅d3	∅d4	L1	L2	L3	L4	L5	L6	L7	U	W
16	2	12.5	23	46	48	46	23	65	M8	4	4	20	6	32	25	16	16	43 ^{+0.1} ₀	56 ^{+0.1} ₀	54	42.5	20	2	2	0.03	0.05
25	4	13	29	58	62	58	29	85	M12	6	6	30	8	45	34	25	25	58 ^{+0.1} ₀	72 ^{+0.1} ₀	70	57	30	2.5	2.5	0.03	0.05
32	6	18	35	70	76	70	35	102	M16	6	8	38	8	60	45	32	32	70 ^{+0.1} ₀	86 ^{+0.1} ₀	83	68.5	30	2.5	2.5	0.03	0.1
40	7.5	19.5	42.5	85	92.5	85	42.5	125	M20	6	10	46	8	75	55	40	40	87 ^{+0.1} ₀	106 ^{+0.1} ₀	102	84.5	30	3	3	0.05	0.1
50	8	20	50	100	108	100	50	140	M20	8	10	46	8	90	68	50	50	100 ^{+0.1} ₀	122 ^{+0.1} ₀	117	97.5	35	3	4	0.05	0.1

11 INSTALLATION DIMENSIONS [mm]

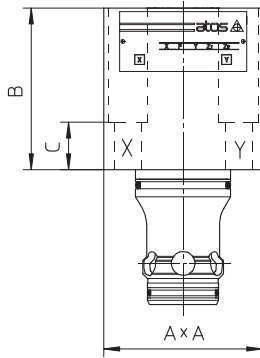

LIDAS					
Size	A	B	C	Fastening bolts class 12.9	Weight (Kg)
16	65	77	64	N°4 M8x80 35 Nm	2,65
25	85	95	75	N°4 M12x95 125 Nm	5,20
32	100	105	85	N°4 M16x105 300 Nm	7,30
40	125	102	70	N°4 M20x70 600 Nm	13,50
50	140	122	49	N°4 M20x80 600 Nm	18,80

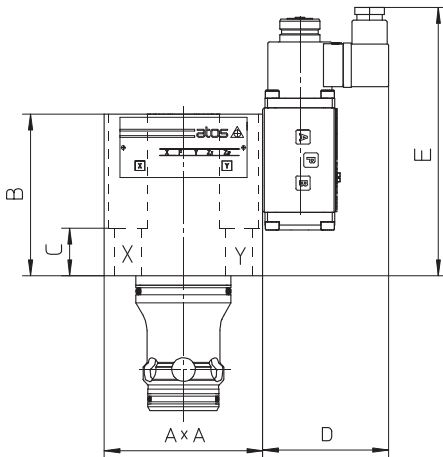

LIDASH							
Size	A	B	C	D	E	Fastening bolts class 12.9	Weight (Kg)
16	72x65	92	64	79,5	155	N°4 M8x80 35 Nm	4,15
25	85	105	77	79,5	170	N°4 M12x95 125 Nm	6,70
32	100	115	85	79,5	180	N°4 M16x105 300 Nm	8,80
40	125	120	39	79,5	185	N°4 M20x70 600 Nm	15,00
50	140	132	49	79,5	190	N°4 M20x80 600 Nm	20,30

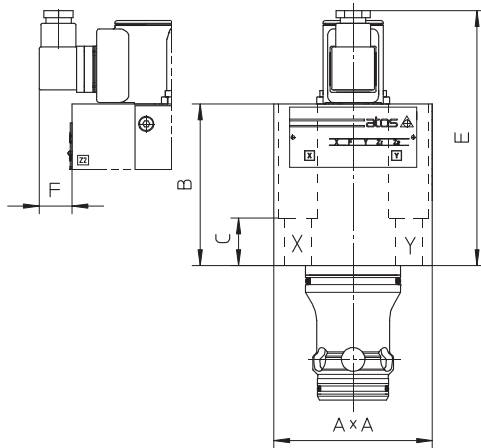

LIDAS-/FI/FC								
Size	A	B	C	D	E	F	Fastening bolts class 12.9	Weight (Kg)
16	65	85	64	-	145	50,5	N°4 M8x80 35 Nm	2,75
25	85	98	75	-	158	40,5	N°4 M12x95 125 Nm	5,30
32	100	107	85	-	168	33	N°4 M16x105 300 Nm	7,40
40	125	110	39	-	170	20,5	N°4 M20x70 600 Nm	13,60
50	140	130	49	-	190	13	N°4 M20x80 600 Nm	19,80

Notes:
 - the valves are supplied with connector SP-666 for /FI and /FC sensors
 - optional connector SP-666/M12 available for /FI and /FC sensors - see section 7

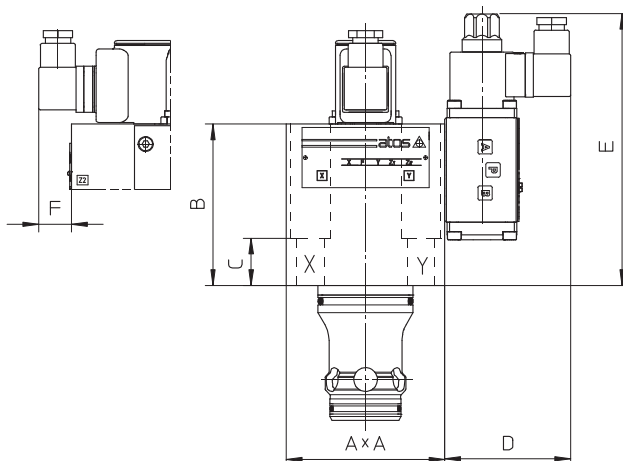

LIDASH-/FI/FC								
Size	A	B	C	D	E	F	Fastening bolts class 12.9	Weight (Kg)
16	72x65	90	64	79,5	159	50,5	N°4 M8x80 35 Nm	4,25
25	85	108	77	79,5	173	40,5	N°4 M12x95 125 Nm	6,80
32	100	112	85	79,5	183	33	N°4 M16x105 300 Nm	8,90
40	125	125	39	79,5	188	20,5	N°4 M20x70 600 Nm	15,10
50	140	135	49	79,5	193	13	N°4 M20x80 600 Nm	21,30