

# Proportional directional valves type DPZO-T\*

two stage, with position transducer, ISO 4401 sizes 10, 16 and 25

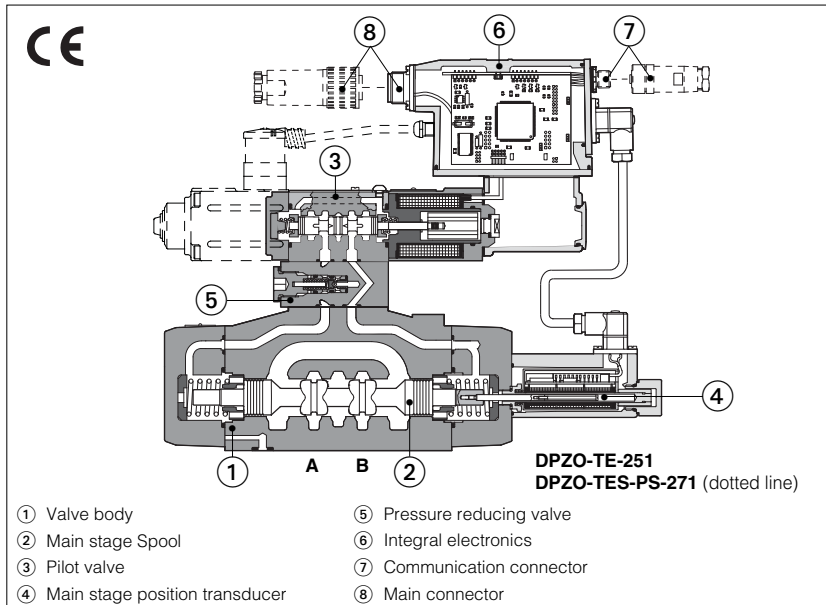

## 1 MODEL CODE

**DPZO -TES -PS - 2 7 1 - L 5 / \* / \*\* / \***

Piloted proportional directional valve			Synthetic fluids <b>WG</b> = water-glycol <b>PE</b> = phosphate ester
<b>T</b> = with position transducer <b>TE</b> = as T plus integral analog electronics <b>TES</b> = as L plus integral digital electronics			Series number
Communication interfaces (only for TES) <b>PS</b> = RS232 serial <b>BC</b> = CANbus <b>BP</b> = PROFIBUS-DP			<b>Hydraulic options, see section 4:</b> <b>B</b> = solenoid, integral electronics and position transducer at side of port A of the main stage <b>E</b> = external pilot (through port X) <b>D</b> = internal drain <b>Electronic options for -TE execution see section 7:</b> <b>F</b> = fault signal <b>I</b> = current reference input and monitor (4±20 mA) <b>Q</b> = enable signal <b>Z</b> = enable, fault and monitor signal <b>Electronic options for -TES execution see section 9:</b> <b>I</b> = current reference input and monitor (4±20 mA) <b>Z</b> = double power supply, enable, fault and monitor <b>Special options for -TES execution see section 9:</b> <b>SF</b> = additional closed loop force control, with two remote pressure transducers <b>SL</b> = additional closed loop force control with one remote load cell <b>SP</b> = additional closed loop pressure control with one remote pressure transducer <b>C</b> = current feedback interface for transducer(s) <b>only for options /SF, /SL, /SP</b>
Valve size: <b>1</b> = 10; <b>2</b> = 16; <b>3</b> = 25			
Configuration, see section 3 <b>5</b> = external plus central position, spring centered <b>7</b> = 3 position, spring centered			
Spool overlapping in central position, see section 3 <b>1</b> = P, A, B, T with positive overlapping (1) <b>3</b> = P positive overlapping (1); A, B, T, negative overlapping			
Spool type (regulating characteristics): <b>L</b> = linear; <b>S</b> = progressive; <b>D</b> = differential-progressive (as <b>S</b> , but with P-A = Q, P-B = Q/2) <b>DL</b> = differential-linear (as <b>L</b> , but with P-A = Q, P-B = Q/2) <b>V</b> = differential - linear (2)			
Spool size: <b>3, 5, 9</b> see section 3			

### Notes:

- (1) Overlapping = 20% of spool stroke for type S; 15% of spool stroke for type L
- (2) The spool type V is available only in size 9 for additional closed loop pressure controls, see section 13.1

## 2 ELECTRONIC DRIVERS

Valve model	-T	-TE	-TES
Drivers model	E-ME-T	E-RI-TE	E-RI-TES
Data sheet	G140	G200	G210

**Note:** For power supply and communication connector see section 16

DPZO-T\* are two stage proportional valves with position transducer on the main spool which provide both directional and non compensated flow control according to electronic reference signal.

They operate in association with electronic drivers, see section 2, which supply the proportional valves with proper current to align valve regulation to the reference signal supplied to the electronic driver.

They are available in different executions:

- -T, with position transducers ④;
- -TE, -TES as -T plus analog (TE) or digital (TES) integral electronics ⑥.

The 4-way spool ②, sliding into a 5-chambers body ①, is piloted by a proportional directional valve ③ type DHZO (see tab. F160) and it is controlled in closed loop position by means of the LVDT transducer ④.

The pressure reducing valve ⑤ with fixed setting ensures a constant piloting pressure.

The integral electronics ⑥ ensures factory presetting, fine functionality plus valve-to-valve interchangeability and simplified wiring and installation. The electronic main connector ⑧ is fully interchangeable for -TE and -TES executions.

Standard 7 pin main connector is used for power supply, analog input reference and monitor signals.

12 pin connector is used for options /Z and /S\*.

The special /S\* options add a closed loop control of pressure (/SP) or force (/SF and /SL) to the basic closed loop spool position one.

Following communication interfaces ⑦ are available for the digital -TES execution:

- -PS, Serial communication interface. The valve reference signal is provided with analogue commands
- -BC, CANopen interface
- -BP, PROFIBUS DP interface

The valves with -BC and -BP interfaces can be integrated into a fieldbus communication network and thus digitally operated by the machine control unit.

The coils are fully plastic encapsulated (insulation class H) and the valves have antivibration, antishock and weather-proof features.

Mounting surface: ISO 4401 sizes 10, 16 and 25.

Max flow respectively up to 160 l/min, 340 l/min and 680 l/min with valve differential pressure  $\Delta p = 30$  bar, see table 2.

Max pressure: 350 bar.

### 3 HYDRAULIC CHARACTERISTICS OF STANDARD SPOOL (based on mineral oil ISO VG 46 at 50 °C)

Standard spools - hydraulic symbols															
Valve model	DPZO-T*-1				DPZO-T*-2				DPZO-T*-3						
Spool overlapping	1, 3				1, 3				1, 3						
Spool type and size	L5	S5	D5	DL5	L3	S3	D3	L5	S5	D5	DL5	L5	S5	D5	DL5
Max flow: [l/min]															
at $\Delta p = 10$ bar	100				130				200						
at $\Delta p = 30$ bar	160				225				340						

Specific spools - hydraulic symbols															
Valve model	DPZO-T*-1				DPZO-T*-2				DPZO-T*-3						
Spool overlapping	1, 3		3		1, 3		3		1, 3		3				
Spool type and size	D9		V9		D9		L9		V9		D9		V9		
Max flow: [l/min]															
at $\Delta p = 10$ bar	100:60		100		200:150		200		390:240		390				
at $\Delta p = 30$ bar	160:100		160		340:250		340		680:410		680				
Pressure limits [bar]	ports P, A, B, X = 350; T = 250; Y = 0														
Response time [ms]	< 60				< 75				< 80						
Hysteresis [%]					$\leq 1\%$										
Repeatability					$\pm 0,5\%$										
Thermal drift	zero point displacement < 1% at $\Delta T = 40^\circ C$														

#### Notes:

- Above performance data refer to valves coupled with Atos electronic drivers, see section 2.
- In case of long time shutdown of the hydraulic supply to the pilot valve, the driver has to be switched off to avoid its overheating.

### 4 HYDRAULIC OPTIONS

**4.1 Option /B** Solenoid, integral electronics and position transducer at side of port A of the main stage.

**4.2 Pilot and drain configuration** -The pilot / drain configuration can be modified as shown in the table E080 section 12.

The valve's standard configuration provides internal pilot and external drain. For different pilot / drain configuration select:

**Option /E** External pilot (through port X). **Option /D** Internal drain.

### 5 GENERAL NOTES

DPZO-T\* proportional valves are CE marked according to the applicable Directives (e.g. Immunity/Emission EMC Directive and Low Voltage Directive).

Installation, wirings and start-up procedures must be performed according to the general prescriptions shown in table F003 and in the installation notes supplied with relevant components.

The electrical signals of the valve (e.g. monitor signals) must not be directly used to activate safety functions, like to switch-ON/OFF the machine's safety components, as prescribed by the European standards (Safety requirements of fluid technology systems and components-hydraulics, EN-892).

### 6 CONNECTIONS FOR -T EXECUTION

SOLENOID POWER SUPPLY CONNECTOR	
PIN	Signal description
1	SUPPLY
2	SUPPLY
3	GND

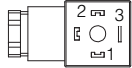

POSITION TRANSDUCER CONNECTOR	
PIN	Signal description
1	OUTPUT SIGNAL
2	SUPPLY -15 Vdc
3	SUPPLY +15 Vdc
4	GND

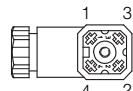

### 7 ANALOG INTEGRAL DRIVERS -TE - OPTIONS

Standard driver execution provides on the 7 pin main connector:

**Power supply** - 24Vdc must be appropriately stabilized or rectified and filtered; a 2,5 A safety fuse is required in series to the driver power supply. Apply at least a 10000  $\mu F/40$  V capacitance to single phase rectifiers or a 4700  $\mu F/40$  V capacitance to three phase rectifiers

**Reference input signal** - analogue differential input with  $\pm 10$  Vdc nominal range (pin D,E), proportional to desired valve spool position

**Monitor output signal** - analogue output signal proportional to the actual valve's spool position with  $\pm 10$  Vdc nominal range

Following options are available to adapt standard execution to special application requirements:

#### 7.1 Option /F

It provides a Fault output signal in place of the Monitor output signal, to indicate fault conditions of the driver (cable interruption of spool transducers or reference signal - for /I option): Fault presence corresponds to 0 Vdc, normal working corresponds to 24 Vdc.

#### 7.2 Option /I

It provides the 4 $\pm$ 20 mA current reference and monitor signals instead of the standard  $\pm 10$  Vdc

It is normally used in case of long distance between the machine control unit and the valve or where the reference signal can be affected by electrical noise; the valve functioning is disabled in case of reference signal cable breakage.

#### 7.3 Option /Q

It provides the possibility to enable or disable the valve functioning without cutting the power supply (the valve functioning is disabled but the driver current output stage is still active). To enable the driver supply a 24Vdc on the enable input signal.

#### 7.4 Option /Z

This option includes /F and /Q features, plus the Monitor output signal.

When the driver is disabled (0 Vdc on Enable signal) Fault output is forced to 0 Vdc.

**7.5 Possible combined options:** /FI and /IZ

## 8 ANALOG INTEGRAL DRIVERS -TE - MAIN FUNCTIONS AND ELECTRONIC CONNECTIONS

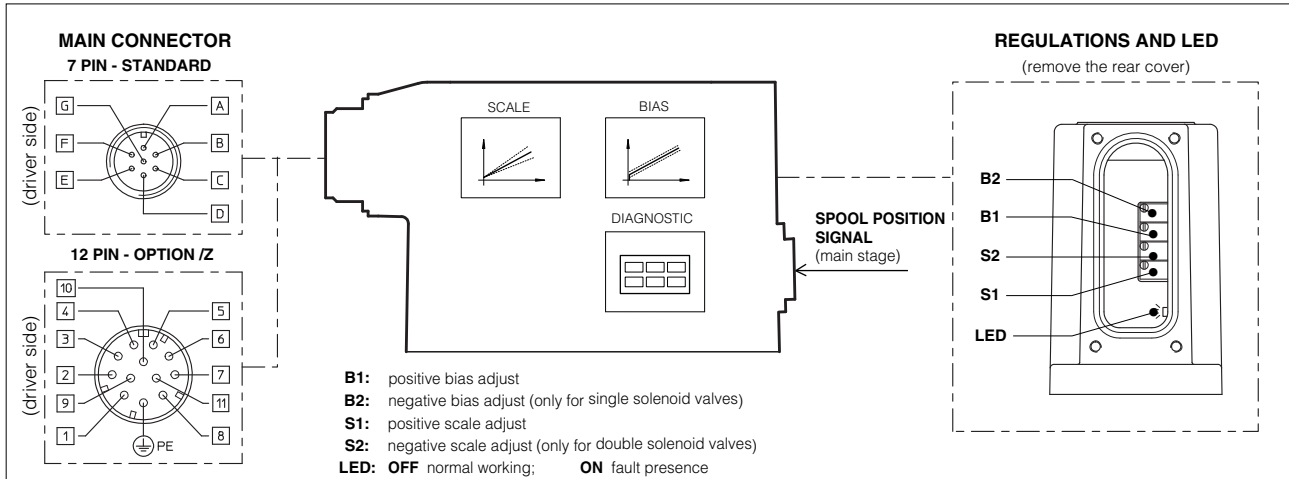

### 8.1 ELECTRONIC CONNECTIONS - 7 & 12 PIN MAIN CONNECTORS

Standard 7pin	/Z option 12pin	SIGNAL	TECHNICAL SPECIFICATIONS	NOTES
A	1	V+	Power supply 24 Vdc for solenoid power stage and driver logic	Input - power supply
B	2	V0	Power supply 0 Vdc for solenoid power stage and driver logic	Gnd - power supply
C <sup>(1)</sup>	7	AGND	Ground - signal zero for MONITOR signal (for standard, /Z option)	Input - analog signal
	3	ENABLE	Enable (24 Vdc) or disable (0 Vdc) the driver (for /Q and /Z options)	Input - on/off signal
D	4	INPUT+	Reference analog differential input: $\pm 10$ Vdc maximum range (4 $\div$ 20 mA for /I option)	Input - analog signal
E	5	INPUT -	For single solenoid valves the reference input is 0 $\div$ +10 Vdc (4 $\div$ 20 mA for /I option) For double solenoid valves the reference input is $\pm 10$ Vdc (4 $\div$ 20 mA for /I option)	
F <sup>(2)</sup>	6	MONITOR	Monitor analog output: $\pm 10$ Vdc maximum range (4 $\div$ 20 mA for /I option)	Output - analog signal
	11	FAULT	Fault (0V) or normal working (24V) (for /F and /Z option)	Output - on/off signal
-	8	R_ENABLE	Repeat Enable - output repetition of Enable input	Output - on/off signal
-	9	NC	do not connect	Output - on/off signal
-	10	NC	do not connect	Output - on/off signal
G	PE	EARTH	Internally connected to the driver housing	

#### Notes:

(1) with /Q option ENABLE signal replaces AGND on pin C; MONITOR signal is referred to pin B

(2) with /F option FAULT signal replaces MONITOR on pin F.

- A minimum time of 50ms to 100ms have be considered between the driver energizing with the 24 Vdc power supply and when the valve is ready to operate. During this time the current to the valve coils is switched to zero.

## 9 DIGITAL INTEGRAL DRIVERS -TES - OPTIONS

Standard driver execution provides on the 7 pin main connector:

- Power supply** - 24Vdc must be appropriately stabilized or rectified and filtered; a 2,5 A safety fuse is required in series to each driver power supply  
Apply at least a 10000  $\mu$ F/40 V capacitance to single phase rectifiers or a 4700  $\mu$ F/40 V capacitance to three phase rectifiers
- Reference input signal** - analogue differential input with  $\pm 10$ Vdc nominal range (pin D,E), proportional to desired valve spool position
- Monitor output signal** - analog output signal proportional to the actual valve's spool position with  $\pm 10$ Vdc nominal range

Following options are available to adapt standard execution to application requirements:

### 9.1 Option /I

It provides 4 $\div$ 20 mA current reference and monitor signals instead of the standard  $\pm 10$  V.

It is normally used in case of long distance between the machine control unit and the valve or where the reference signal can be affected by electrical noise; the valve functioning is disabled in case of reference signal cable breakage.

### 9.2 Option /Z

It provides on a 12 pin main connector the above standard features plus:

#### Logic power supply

Option /Z provides separate power supply for the solenoid (pin 1, 2) and for the digital electronic circuits (pin 9, 10).

Cutting solenoid power supply allows to interrupt the valve functioning but keeping energized the digital electronics thus avoiding fault conditions of the machine fieldbus controller (e.g. for emergency, as provided by the European Norms EN954-1 for components with safety class 2).

#### Enable Input Signal

To enable the driver, supply a 24Vdc on pin 3 referred to pin 2: when the Enable signal is set to zero the valve functioning is disabled (zero current to the solenoid) but the driver current output stage is still active. This condition does not comply with European Norms EN954-1.

#### Fault Output Signal

Fault output signal indicates fault conditions of the driver (solenoid short circuits/not connected, reference signal cable broken for 4 $\div$ 20mA input, etc.). Fault presence corresponds to 0 Vdc, normal working corresponds to 24Vdc (pin 11 referred to pin 2): Fault status is not affected by the Enable input signal

### 9.3 Options /SP, /SF and /SL

These options add the closed loop control of pressure (/SP) or force (/SF and /SL) to the basic functions of proportional directional valves: a dedicated software alternates pressure (force) and valve's spool position controls depending on the actual hydraulic system conditions.

A dedicated connector is available for the additional transducers that are required to be interfaced to the valve's driver (1 pressure transducer for /SP, 2 pressure transducers for /SF or 1 load cell for /SL).

Main 12 pin connector is the same as /Z option plus two analog signals specific for the pressure (force) control: one for reference (pin 7) and one for monitor (pin 8).

For further details please refer to the driver technical table **G210, section 13**.

### 9.4 Options /C

Options /CSP, /CSF and /CSL are available to connect pressure (force) transducers with 4  $\div$  20mA current output signal.

### 9.5 Possible combined options: /CSP, /CSF, /CSL, /CISP, /CISF, /CISL and /IZ

## 10 DIGITAL INTEGRAL DRIVERS -TES - MAIN FUNCTIONS AND ELECTRONIC CONNECTIONS

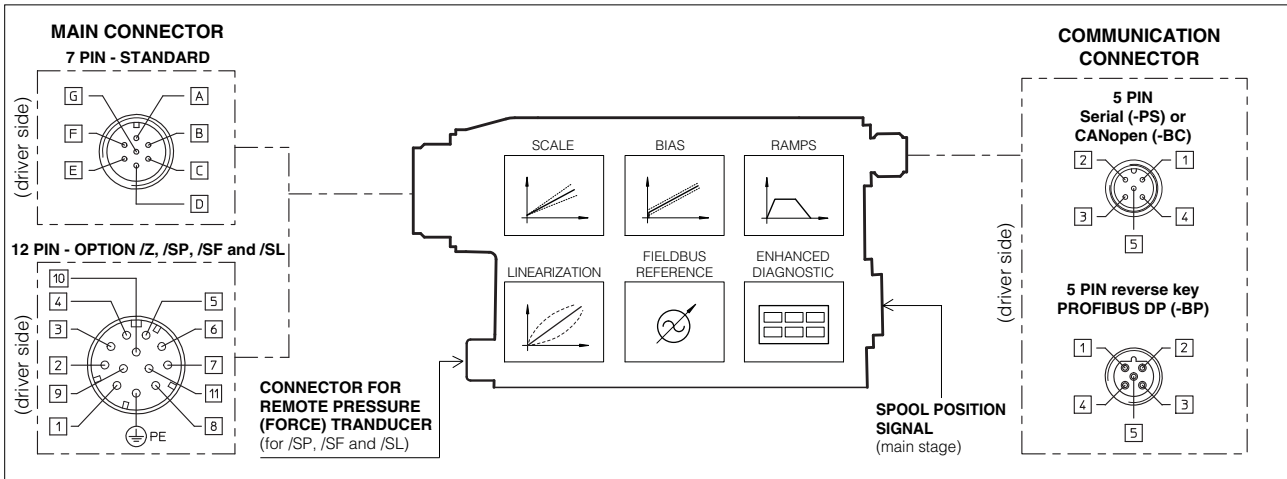

### 10.1 ELECTRONIC CONNECTIONS - 7 & 12 PIN MAIN CONNECTORS

Standard 7pin	/Z option 12pin	SIGNAL	TECHNICAL SPECIFICATIONS	NOTES
A	1	V+	Power supply 24 Vdc for solenoid power stage (and for driver logic on 7 pin connection)	Input - power supply
B	2	V0	Power supply 0 Vdc for solenoid power stage (and for driver logic on 7 pin connection)	Gnd - power supply
-	3	ENABLE	Enable (24 Vdc) or disable (0 Vdc) the driver	Input - on/off signal
D	4	INPUT+	Reference analog input: $\pm 10$ Vdc maximum range (4 $\div$ 20 mA for /I option) For single solenoid valves the reference input is 0 $\div$ +10 Vdc (4 $\div$ 20 mA for /I option) For double solenoid valves the reference input is $\pm 10$ Vdc (4 $\div$ 20 mA for /I option) standard: differential input; /Z option: common mode INPUT+ referred to AGND	Input - analog signal
E	-	INPUT -		
C	5	AGND	Ground - signal zero for MONITOR signal signal zero for INPUT+ signal (only for /Z option)	Gnd - analog signal
F	6	MONITOR	Monitor analog output: $\pm 10$ Vdc maximum range (4 $\div$ 20 mA for /I option)	Output - analog signal
-	7	NC	do not connect (pressure/force input for /SP, /SF and /SL options, see 9.3)	
-	8	NC	do not connect (pressure/force monitor for /SP, /SF and /SL options, see 9.3)	
-	9	VL+	Power supply 24 Vdc for driver logic	Input - power supply
-	10	VLO	Power supply 0 Vdc for driver logic	Gnd - power supply
-	11	FAULT	Fault (0V) or normal working (24V)	Output - on/off signal
G	PE	EARTH	Internally connected to the driver housing	

**Note:** A minimum time of 300 to 500 ms have be considered between the driver energizing with the 24 Vdc power supply and when the valve is ready to operate. During this time the current to the valve coils is switched to zero.

### 10.2 ELECTRONIC CONNECTIONS - 5 PIN COMMUNICATION CONNECTORS

PIN	-PS Serial		-BC CANopen		-BP PROFIBUS DP	
	SIGNAL	TECHNICAL SPECIFICATION	SIGNAL	TECHNICAL SPECIFICATION	SIGNAL	TECHNICAL SPECIFICATION
1	NC	do not connect	CAN_SHLD	Shield	+5V	for termination
2	NC	do not connect	NC	do not connect	LINE-A	Bus line (high)
3	RS_GND	Signal zero data line	CAN_GND	Signal zero data line	DGND	data line and termination Signal zero
4	RS_RX	Valves receiving data line	CAN_H	Bus line (high)	LINE-B	Bus line (low)
5	RS_TX	Valves transmitting data line	CAN_L	Bus line (low)	SHIELD	

## 11 SOFTWARE TOOLS

The functional parameters of the digital valves, as the bias, scale, ramp and linearization of the regulation characteristic, can be easily set and optimized with graphic interface by using the Atos E-SW software and the relevant USB adapters, cable and terminators, **see tab. G500**. Valves with fieldbus communication interface (-BC and -BP) can be completely managed by the machine control unit; it is required to implement in the machine control the standard communication as described in the user manuals supplied with the relevant programming software. For detailed description of available fieldbus features, **see tab. G510**

## 12 MAIN CHARACTERISTICS OF PROPORTIONAL DIRECTIONAL VALVES

Assembly position	Any position
Subplate surface finishing	Roughness index, $\sqrt{Ra}$ flatness ratio 0,01/100 (ISO 1101)
Ambient temperature	-20°C $\div$ +70°C for -T execution; -20°C $\div$ +60°C for -TE and -TES executions
Fluid	Hydraulic oil as per DIN 51524 ... 535 for other fluids see section 11
Recommended viscosity	15 $\div$ 100 mm <sup>2</sup> /s at 40°C (ISO VG 15 $\div$ 100)
Fluid contamination class	ISO 18/15 achieved with in line filters of 10 $\mu$ m and $\beta_{10} \geq 75$ (recommended)
Fluid temperature	-20°C +60°C (standard and /WG seals) -20°C +80°C (/PE seals)
Coil resistance R at 20°C	3 $\div$ 3,3 $\Omega$
Max. solenoid current	2,6 A
Max. power	35 Watt
Insulation class	H (180°) Due to the occurring surface temperatures of the solenoid coils, the European standards ISO 13732-1 and EN982 must be taken into account
Protection degree (CEI EN-60529)	IP65 for -T execution; IP65-67 for -TE and -TES executions, depending to the connector type (see sect. 16 )
Duty factor	Continuous rating (ED=100%)

**13 DIAGRAMS** (based on mineral oil ISO VG 46 at 50 °C)

**13.1 Regulation diagrams**

DPZO-1:

- 1 = 1L5, 1DL5, 3L5, 3DL5
- 2 = 1S5, 1D5, 3S5, 3D5

DPZO-2:

- 3 = 1L5, 1DL5, 3L5, 3DL5
- 4 = 1S5, 1D5, 3S5, 3D5
- 5 = 1L3, 3L3
- 6 = 1S3, 1D3, 3S3, 3D3

DPZO-3:

- 7 = 1L5, 1DL5, 3L5, 3DL5
- 8 = 1S5, 1D5, 3S5, 3D5

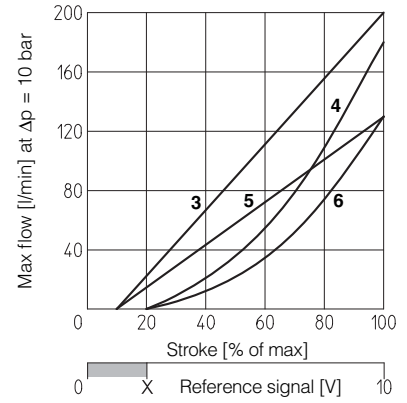
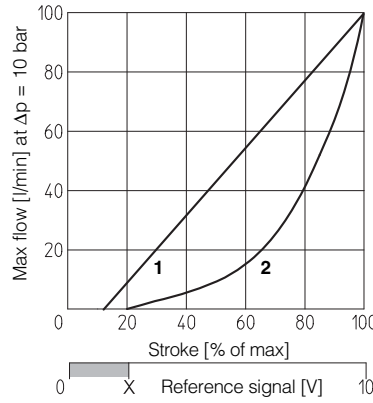

**X** = Threshold for bias activation depending to the valve type and amplifier type

**Note:**

Hydraulic configuration vs. reference signal:

Reference signal  $0 \div +10 \text{ V}$   $12 \div 20 \text{ mA}$  P → A / B → T

Reference signal  $0 \div -10 \text{ V}$   $4 \div 12 \text{ mA}$  P → B / A → T

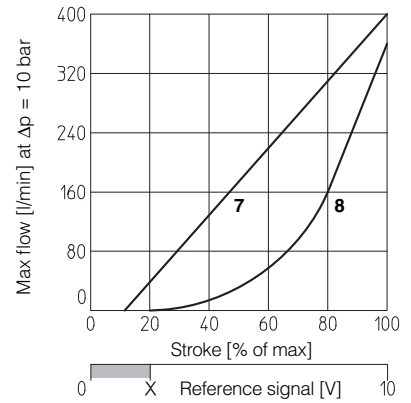

**X** = Threshold for bias activation depending to the valve type and amplifier type

**9** = differential - regenerative spool D9

D9 spool type with a fourth position specific to regenerative circuit, performed by means of an additional external check valve.

Application example

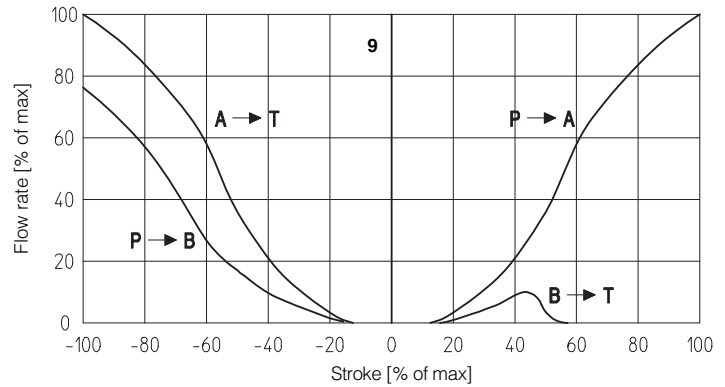
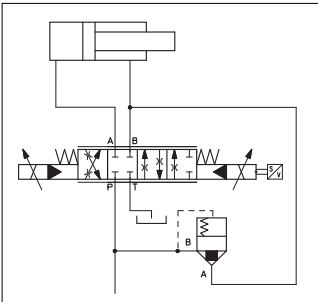

**10** = linear - internal regenerative spool L9

L9 spool type with a fourth position specific to regenerative circuit internal to the valve.

- 1 = P - B
- 2 = A - T
- 3 = P - A
- 4 = B - T
- 5 = P - B (regenerative)

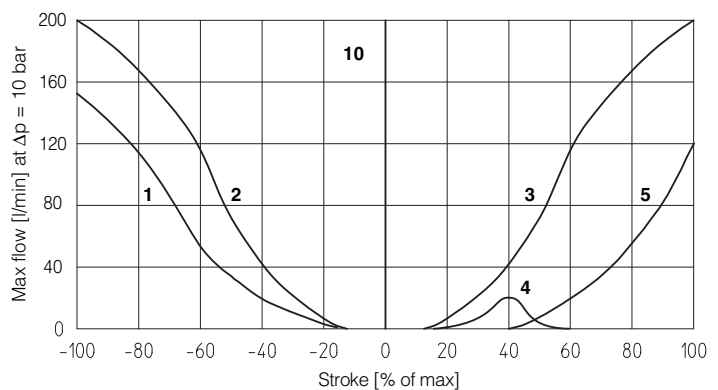

11 = differential - linear spool V9

V9 spool type specific for alternate P/Q controls in combination with option /SP of digital integral drivers, see tab. G210 section 13

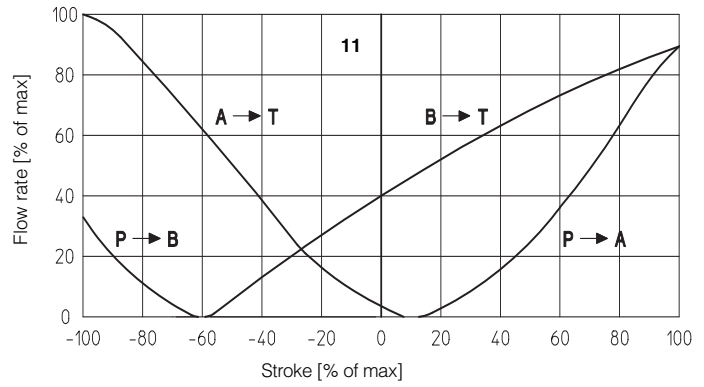

**13.2 Operating diagrams**

**Flow /Δp diagram**

stated at 100% of spool stroke

DPZO-1:

1 = spools L5, S5, D5, DL5, D9, V9

DPZO-2:

2 = spools L5, S5, D5, DL5, D9, L9, V9

3 = spool L3, S3, D3

DPZO-3:

4 = spools L5, S5, D5, DL5, D9, V9

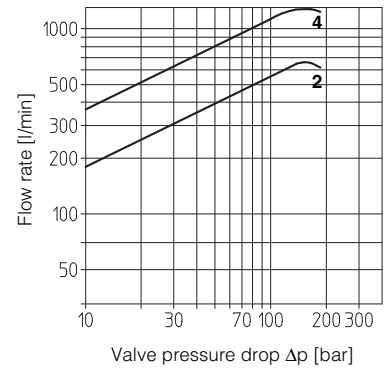
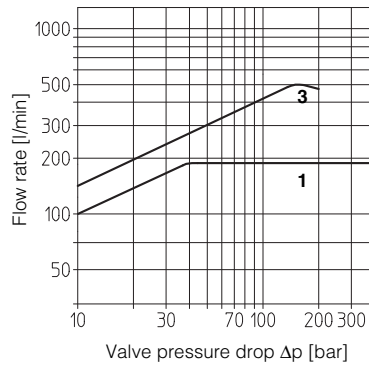

**13.5 Dynamic response**

The response times in section 3 have to be considered as average values.

For the valves with digital electronics the dynamics performances can be optimized by setting the internal software parameters.

**13.6 Operation as throttle valve**

Single solenoid valves (\*51) can be used as simple throttle valves:  
Pmax = 250 bar

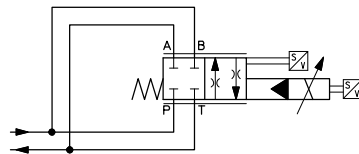

DPZO-*	151-L5	251-L5	351-L5
Max flow [l/min]	300	650	1200
Δp [bar]	50	55	50

**DPZO-T(\*)-1** (dotted line = double solenoid version)

**DPZO-T-1**

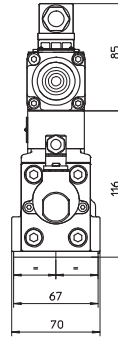
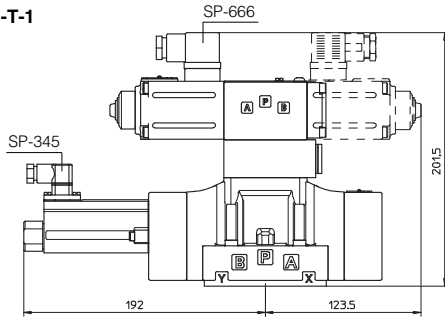

**ISO 4401: 2005**

**Mounting surface: 4401-05-05-0-05** (see table P005)

Fastening bolts:

4 socket head screws M6x40 class 12.9

Tightening torque = 15 Nm

Seals: 5 OR 2050; 2 OR 108

Diameter of ports A, B, P, T:  $\varnothing = 11$  mm;

Diameter of ports X, Y:  $\varnothing = 5$  mm;

**Mass [kg]**

	T	TE, TES
DPZO-* -15*	7,7	8,1
DPZO-* -17*	8,6	9,1

**DPZO-TE-1**

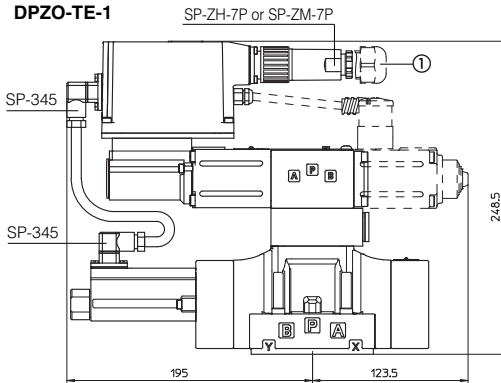

**-TE EXECUTION**

① = 12 pin connector SP-ZH-12P for option /Z

**DPZO-TES\*-1**

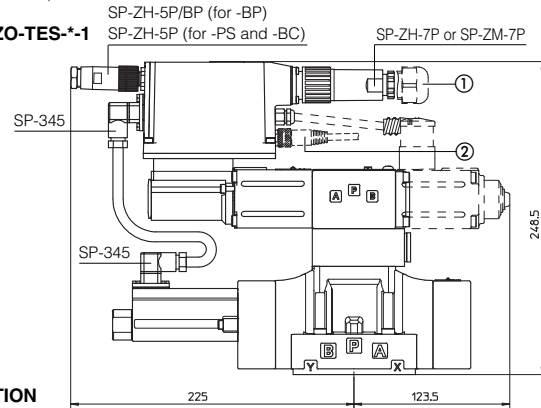

**-TES EXECUTION**

① = 12 pin connector SP-ZH-12P for options /SF, /SL, /SP, /Z

② = M8 connector SP-ZH-4P-M8/5 moulded on cable 5 mt length for pressure or force transducer (options /SL, /SP)

M8 connector SP-ZH-4P-M8/2-2 moulded with 2 cables, 2 mt length for 2 pressure transducers (options /SF)

**NOTE:**

For option /B the proportional solenoid, the position transducer and the electronics (in case of execution -TE and -TES) are at side of port A of the main stage.

**DPZO-T(\*)-2** (dotted line = double solenoid version)

**DPZO-T-2**

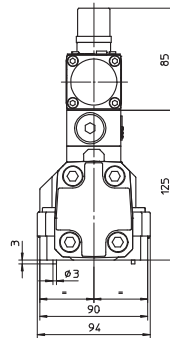
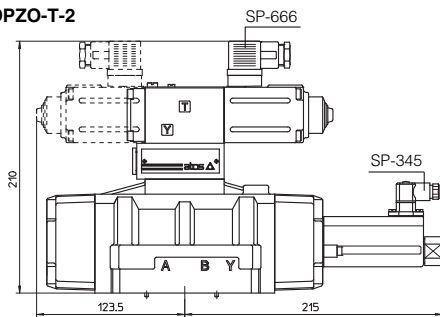

**ISO 4401: 2005**

**Mounting surface: 4401-07-07-0-05** (see table P005)

Fastening bolts:

4 socket head screws M10x50 class 12.9

Tightening torque = 70 Nm

2 socket head screws M6x40 class 12.9

Tightening torque = 15 Nm

Seals: 4 OR 130; 3 OR 109/70

Diameter of ports A, B, P, T:  $\varnothing = 20$  mm;

Diameter of ports X, Y:  $\varnothing = 7$  mm;

**Mass [kg]**

	T	TE, TES
DPZO-* -25*	11,9	12,3
DPZO-* -27*	12,8	13,3

**DPZO-TE-2**

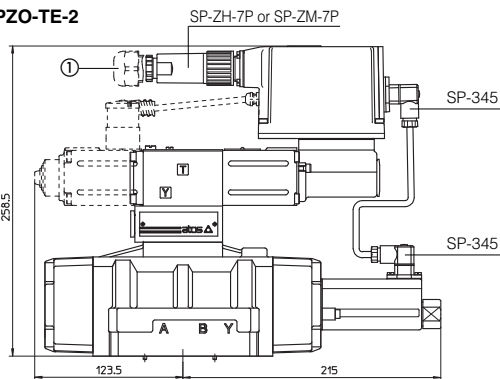

**-TE EXECUTION**

① = 12 pin connector SP-ZH-12P for option /Z

**DPZO-TES\*-2**

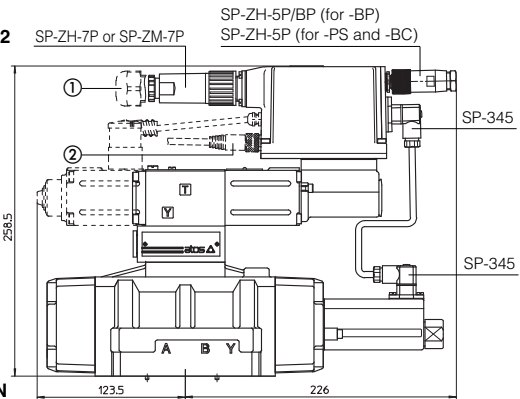

**-TES EXECUTION**

① = 12 pin connector SP-ZH-12P for options /SF, /SL, /SP, /Z

② = M8 connector SP-ZH-4P-M8/5 moulded on cable 5 mt length for pressure or force transducer (options /SL, /SP)

M8 connector SP-ZH-4P-M8/2-2 moulded with 2 cables, 2 mt length for 2 pressure transducers (options /SF)

**NOTE:**

For option /B the proportional solenoid, the position transducer and the electronics (in case of execution -TE and -TES) are at side of port A of the main stage.

10 INSTALLATION DIMENSIONS FOR DPZO-3 [mm]

**DPZO-T(\*)-3** (dotted line = double solenoid version)

**DPZO-T-3**

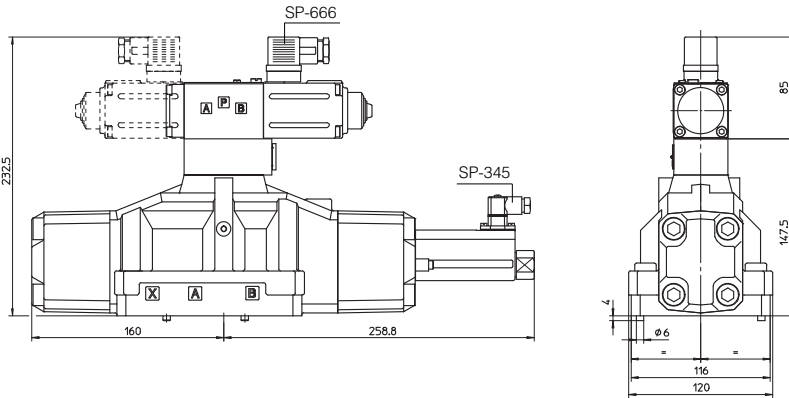

**DPZO-TE-3**

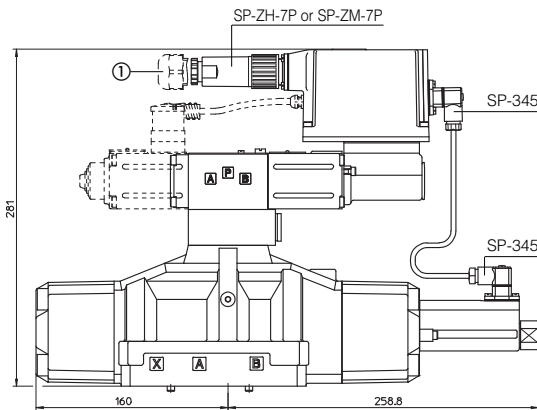

**ISO 4401: 2005**

**Mounting surface: 4401-08-08-0-05** (see table P005)

Fastening bolts:

6 socket head screws M12x50 class 12.9

Tightening torque = 125 Nm

Seals: 4 OR 4112; 3 OR 3056

Diameter of ports A, B, P, T:  $\varnothing = 24$  mm;

Diameter of ports X, Y:  $\varnothing = 7$  mm;

**-TE EXECUTION**

① = 12 pin connector SP-ZH-12P for option /Z

**DPZO-TE-S\*-3**

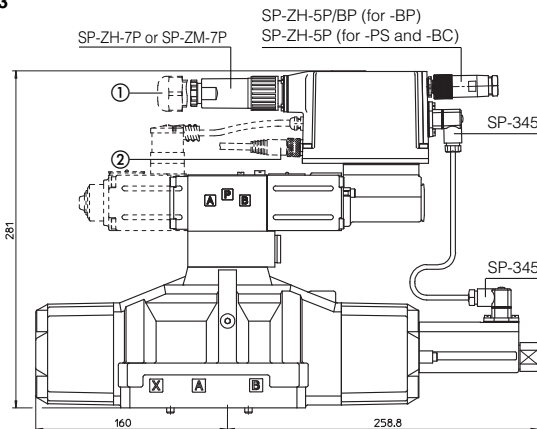

**Mass [kg]**

	T	TE, TES
DPZO-*-35*	17,1	17,5
DPZO-*-37*	18	18,4

**-TES EXECUTION**

① = 12 pin connector SP-ZH-12P for options /SF, /SL, /SP, /Z

② = M8 connector SP-ZH-4P-M8/5 moulded on cable 5 mt length for pressure or force transducer (options /SL, /SP)  
M8 connector SP-ZH-4P-M8/2-2 moulded with 2 cables, 2 mt length for 2 pressure transducers (options /SF)

**NOTE:**

For option /B the proportional solenoid, the position transducer and the electronics (in case of execution -TE and -TES) are at side of port A of the main stage.

16 MODEL CODES OF POWER SUPPLY AND COMMUNICATION CONNECTORS (to be ordered separately)

VALVE VERSION	-T Power supply   Transducer		-TE, -TES		-TE/Z -TES /Z, /SF, /SL, /SP	TES -PS, -BC	TES -BP	TES /SF, /SL, /SP
CONNECTOR CODE	SP-666	SP-345	SP-ZH-7P	SP-ZM-7P	SP-ZH-12P	SP-ZH-5P	SP-ZH-5P/BP	SP-ZH-4P-M8/* (1)
PROTECTION DEGREE	IP65	IP65	IP67	IP67	IP65	IP67	IP67	IP67
DATA SHEET	K500		G200, G210, K500			G210, K500		

(1) M8 connector SP-ZH-4P-M8/5 moulded on cable 5 mt length for pressure or force transducer (options /SL, /SP)

M8 connector SP-ZH-4P-M8/2-2 moulded with 2 cables, 2 mt length for 2 pressure transducers (options /SF)

connectors supplied with the valve