

Proportional directional valves type DHZO-T* and DKZOR-T*

direct operated, with position transducer, ISO 4401 size 06 and 10

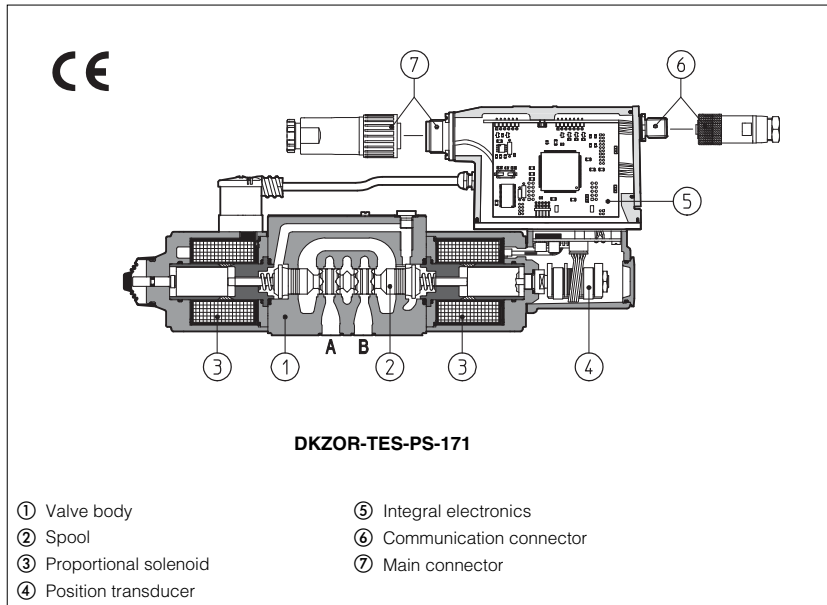

1 MODEL CODE

DHZO - TES - PS - 0 7 1 - S 5 / * / ** / *

<p>DHZO = size 06 DKZOR = size 10</p> <p>T = with position transducer TE = as T plus integral analog electronics TES = as T plus integral digital electronics</p> <p>Communication interfaces (only for TES) PS = Serial BC = CANopen BP = PROFIBUS DP</p> <p>Valve size 0 = ISO 4401 size 06 1 = ISO 4401 size 10</p> <p>Configuration, see section 3 5 = external plus central position, spring centered 7 = 3 position, spring centered</p> <p>Spool overlapping in central position, see section 3 0 = zero overlap (0 to 5 % spool stroke) 1 = P,A,B,T positive overlapping (20% of spool stroke) 2 = P,A,B,T positive overlapping with A-B draining (1) 3 = P positive overlapping (20% of spool stroke); A, B, T, negative</p> <p>Spool type (regulating characteristics) L = linear; S = progressive; D = differential-progressive (as S, but with P-A = Q, P-B = Q/2) V = differential-linear (2)</p> <p>Spool size: 14, 1, 2, 3, 5, 9 = see section 3</p>	<p>Synthetic fluids WG = water-glycol PE = phosphate ester</p> <p>Series number</p> <p>Hydraulic options, see section 4: B = solenoid, integral electronics and position transducer at side of port A Y = external drain</p> <p>Electronics options, for -TE execution see section 7: F = fault signal I = current reference input and monitor (4±20 mA) Q = enable signal K = with logic state signals Z = enable, fault and monitor signals</p> <p>Electronics options, for -TES execution see section 9: I = current reference input and monitor (4±20 mA) Z = double power supply, enable fault and monitor</p> <p>Special options for -TES execution see section 9: SF = additional closed loop force control, with two remote pressure transducers SL = additional closed loop force control with one remote load cell SP = additional closed loop pressure control with one remote pressure transducer C = current feedback interface for transducer(s) only for options /SF, /SL, /SP</p>
---	---

Notes: (1) Only for **DKZOR-S5** the spool overlapping type 2 provides the same characteristic of type 1, but in central position the internal leakages from P to A and B are drained to tank, avoiding the drift of cylinders with differential areas.
(2) The spool type V is available only in size 9 for additional closed loop pressure controls, see section 13.1 and 14.1

2 ELECTRONIC DRIVERS

Valve model	-T	-TE	-TES
Drivers model	E-ME-T	E-RI-TE	E-RI-TES
Data sheet	G140	G200	G210

Note: For power supply and communication connector see section 16 and 18

DHZO-T* and DKZOR-T* are proportional valves, direct operated, with LVDT position transducer, which provide both directional and non-compensated flow control according to the electronic reference signal.

They operate in association with electronic drivers, see section 2, which supply the proportional valves with proper current to align valve regulation to the reference signal supplied to the electronic driver.

They are available in different executions:

- -T, with integral position transducer ④;
- -TE, -TES as -T plus analog (TE) or digital (TES) integral electronics ⑤.

The 4-way spool ②, sliding into a 5-chambers body ①, is directly operated by solenoids ③ and it is controlled in closed loop position by means of the LVDT position transducer ④

The integral electronics ⑤ ensures factory presetting, fine functionality plus valve-to-valve interchangeability and simplified wiring and installation.

The electronic main connector ⑦ is fully interchangeable for -TE and -TES executions.

Standard 7 pin main connector is used for power supply, analog input reference and monitor signals.

12 pin connector is used for options /K, /Z and /S*.

The special /S* options add a closed loop control of pressure (/SP) or force (/SF and /SL) to the basic closed loop spool position one.

Following communication interfaces ⑥ are available for the digital -TES execution:

- -PS, Serial communication interface. The valve reference signal is provided with analogue commands
- -BC, CANopen interface
- -BP, PROFIBUS DP interface

The valves with -BC and -BP interfaces can be integrated into a fieldbus communication network and thus digitally operated by the machine control unit.

The coils are fully plastic encapsulated (insulation class H) and the valves have antivibration, antishock and weather-proof features.

Mounting surface: ISO 4401 sizes 06 and 10.

Max flow respectively up to 50 l/min and 130 l/min with valve differential pressure Δp = 30 bar, see table 3.

Max pressure = 350 bar for DHZO;
315 bar for DKZOR.

3 HYDRAULIC CHARACTERISTICS (based on mineral oil ISO VG 46 at 50 °C)

Hydraulic symbols														
Valve model	DHZO-T*					DKZOR-T*								
Spool overlapping	1, 3			1, 3		1, 3		0			1, 3			
Spool type and size	L14	L1	S2	S3, L3, D3	L3	L5	S5, L5, D5	V9	S3, L3, D3	L3	L5	S5	S5, L5, D5	V9
Pressure limits [bar]	ports P, A, B = 350; T = 160 (250 with external drain /Y)								ports P, A, B = 315; T = 160 (250 with external drain /Y)					
Max flow (1) [l/min]														
at $\Delta p = 10$ bar (P-T)	1	4,5	8	17	28	30	45	75						
at $\Delta p = 30$ bar (P-T)	2	8	14	30	50	52	80	130						
at $\Delta p = 70$ bar (P-T)	3	12	21	45	74	80	120	170						
Response time [ms]	< 15								< 20					
Hysteresis [%]	$\leq 0,2\%$								$\leq 0,2\%$					
Repeatability [%]	$\pm 0,1\%$								$\pm 0,1\%$					
Thermal drift	zero point displacement < 1% at $\Delta T = 40^\circ C$													

Notes:

- Above performance data refer to valves coupled with Atos electronic drivers, see sections 2.
- The flow regulated by the directional proportional valves is not pressure compensated, thus it is affected by the load variations. To keep constant the regulated flow under different load conditions, modular pressure compensators are available (see tab. D150).

4 HYDRAULIC OPTIONS

4.1 Option /B Solenoid (for valve configuration *5*), integral electronics and position transducer at side of port A.

4.2 Option /Y External drain advisable when the valve is used in double flow path, see section 13.5 and 14.5. Option /Y is mandatory if the pressure in port T exceeds 160 bar.

5 GENERAL NOTES

DHZO and DKZOR proportional valves are CE marked according to the applicable Directives (e.g. Immunity/Emission EMC Directive and Low Voltage Directive).

Installation, wirings and start-up procedures must be performed according to the general prescriptions shown in table F003 and in the installation notes supplied with relevant components.

The electrical signals of the valve (e.g. monitor signals) must not be directly used to activate safety functions, like to switch-ON/OFF the machine's safety components, as prescribed by the European standards (Safety requirements of fluid technology systems and components-hydraulics, EN-892).

6 CONNECTIONS FOR -T EXECUTION

SOLENOID POWER SUPPLY CONNECTOR	
PIN	Signal description
1	SUPPLY
2	SUPPLY
3	GND

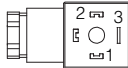

POSITION TRANSDUCER CONNECTOR	
PIN	Signal description
1	OUTPUT SIGNAL
2	SUPPLY -15 V _{DC}
3	SUPPLY +15 V _{DC}
4	GND

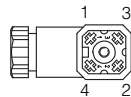

7 ANALOG INTEGRAL DRIVERS -TE - OPTIONS

Standard driver execution provides on the 7 pin main

connector:

Power supply - 24V_{DC} must be appropriately stabilized or rectified and filtered; a 2,5 A safety fuse is required in series to the driver power supply. Apply at least a 10000 $\mu F/40$ V capacitance to single phase rectifiers or a 4700 $\mu F/40$ V capacitance to three phase rectifiers

Reference input signal - analog differential input with ± 10 V_{DC} nominal range (pin D,E), proportional to desired valve spool position

Monitor output signal - analog output signal proportional to the actual valve's spool position with ± 10 V_{DC} nominal range

Following options are available to adapt standard execution to special application requirements:

7.1 Option /F

It provides a Fault output signal in place of the Monitor output signal, to indicate fault conditions of the driver (cable interruption of spool transducers or reference signal - for /I option): Fault presence corresponds to 0 V_{DC}, normal working corresponds to 24 V_{DC}.

7.2 Option /I

It provides the 4÷20 mA current reference and monitor signals instead of the standard ± 10 V_{DC}

It is normally used in case of long distance between the machine control unit and the valve or where the reference signal can be affected by electrical noise; the valve functioning is disabled in case of reference signal cable breakage.

7.3 Option /Q

It provides the possibility to enable or disable the valve functioning without cutting the power supply (the valve functioning is disabled but the driver current output stage is still active). To enable the driver supply a 24V_{DC} on the enable input signal.

7.4 Option /Z

This option includes /F and /Q features, plus the Monitor output signal.

When the driver is disabled (0 V_{DC} on enable signal) Fault option is forced to 0 V_{DC}.

7.5 Option /K (only for DHZO-TE-071* and DKZOR-TE-171*)

This option provides, by means of four ON/OFF output signals, a real time monitor of the valve's hydraulic regulation (P-A, P-B or Central) and of the solenoid energizing status.

It can be used to improve the system safety level, by interfacing the four signals to a specific CE certified electronics: beside the standard safety valves the machine CNC can also recognize the proportional valve regulation during the working cycle.

The valve regulation is identified by the contemporaneous status on the four signals, as shown in the beside diagram. The central position indicates no hydraulic regulation: "central position window" is located across the valve's mechanical zero within $\pm 5\%$ of the total stroke and it provides a reliable information about the actuator stopped condition (valve's spools have a nominal positive overlap of $\pm 20\%$ of total stroke). The signal on pin 8 identifies the solenoid energizing status and depends on enable signal status (see 6.3): "0" = coil current active and "1" = coil current zero (enable signal must be 0V_{DC}).

For all signals, the logic state "0" produces an output voltage signal ≤ 1 V_{DC} while the logic state "1" produces an output voltage signal ≥ 22 V_{DC}.

State Signals

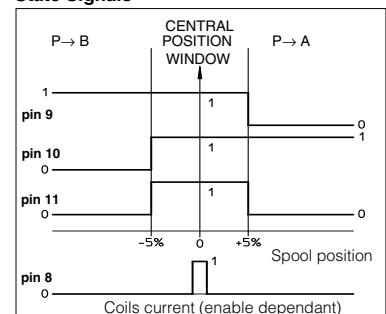

7.6 Possible combined options: /FI, /IK and /IZ

8 ANALOG INTEGRAL DRIVERS -TE - MAIN FUNCTIONS AND ELECTRONIC CONNECTIONS

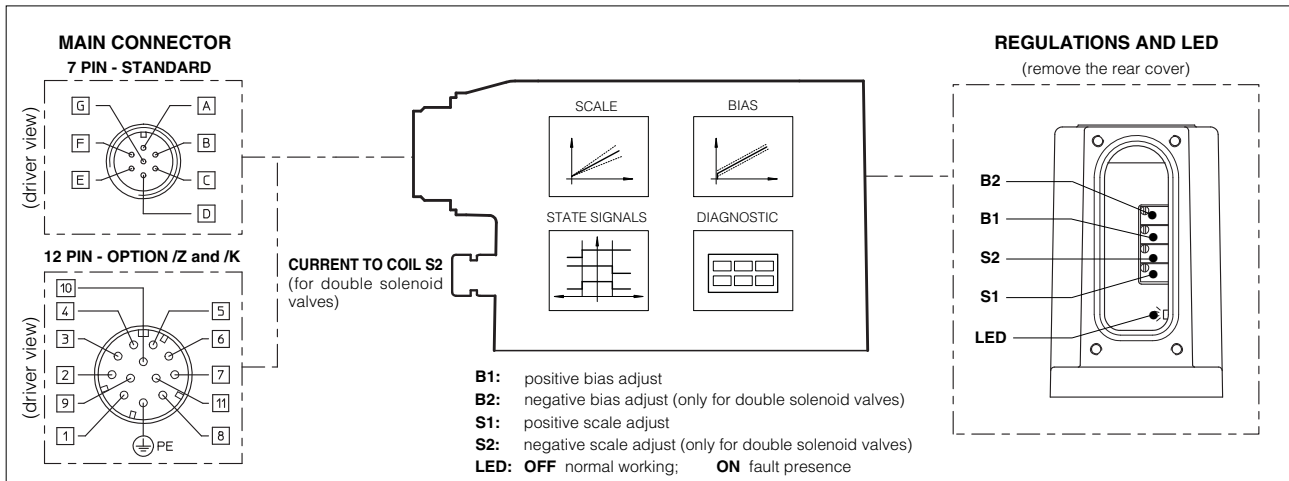

8.1 ELECTRONIC CONNECTIONS - 7 & 12 PIN MAIN CONNECTORS

Standard 7pin	/Z,/K option 12pin	SIGNAL	TECHNICAL SPECIFICATIONS	NOTES
A	1	V+	Power supply 24 Vdc for solenoid power stage and driver logic	Input - power supply
B	2	V0	Power supply 0 Vdc for solenoid power stage and driver logic	Gnd - power supply
C (1)	7	AGND	Ground - signal zero for MONITOR signal (for standard, /Z and /K options)	Input - analog signal
	3	ENABLE	Enable (24 Vdc) or disable (0 Vdc) the driver (for /Q, /Z and /K options)	Input - on/off signal
D	4	INPUT+	Reference analog differential input: ± 10 Vdc maximum range (4 \div 20 mA for /I option)	Input - analog signal
E	5	INPUT -	For single solenoid valves the reference input is 0 \div +10 Vdc (4 \div 20 mA for /I option) For double solenoid valves the reference input is ± 10 Vdc (4 \div 20 mA for /I option)	
F (2)	6	MONITOR	Monitor analog output: ± 10 Vdc maximum range (4 \div 20 mA for /I option)	Output - analog signal
	11	FAULT	Fault (0V) or normal working (24V) (for /F and /Z, see 7.5 for /K option)	Output - on/off signal
-	8	R_ENABLE	Repeat Enable - output repetition of Enable input (see 7.5, for /K option)	Output - on/off signal
-	9	NC	do not connect (see 7.5, for /K option)	Output - on/off signal
-	10	NC	do not connect (see 7.5, for /K option)	Output - on/off signal
G	PE	EARTH	Internally connected to the driver housing	

Notes

(1) with /Q option ENABLE signal replaces AGND on pin C; MONITOR signal is referred to pin B

(2) with /F option FAULT signal replaces MONITOR on pin F.

- A minimum time of 50ms to 100ms have be considered between the driver energizing with the 24 Vdc power supply and when the valve is ready to operate. During this time the current to the valve coils is switched to zero.

9 DIGITAL INTEGRAL DRIVERS -TES - OPTIONS

Standard driver execution provides on the 7 pin main connector:

- Power supply** - 24Vdc must be appropriately stabilized or rectified and filtered; a 2,5 A safety fuse is required in series to each driver power supply
Apply at least a 10000 μ F/40 V capacitance to single phase rectifiers or a 4700 μ F/40 V capacitance to three phase rectifiers.
- Reference input signal** - analogue differential input with ± 10 Vdc nominal range (pin D,E), proportional to desired valve spool position
- Monitor output signal** - analog output signal proportional to the actual valve's spool position with ± 10 Vdc nominal range

Following options are available to adapt standard execution to special application requirements:

9.1 Option /I

It provides 4 \div 20 mA current reference and monitor signals instead of the standard ± 10 V.

It is normally used in case of long distance between the machine control unit and the valve or where the reference signal can be affected by electrical noise; the valve functioning is disabled in case of reference signal cable breakage.

9.2 Option /Z

It provides on a 12 pin main connector the above standard features plus:

Logic power supply

Option /Z provides separate power supply for the solenoid (pin 1, 2) and for the digital electronic circuits (pin 9, 10).

Cutting solenoid power supply allows to interrupt the valve functioning but keeping energized the digital electronics thus avoiding fault conditions of the machine fieldbus controller (e.g. for emergency, as provided by the European Norms EN954-1 for components with safety class 2).

Enable Input Signal

To enable the driver, supply a 24Vdc on pin 3 referred to pin 2: when the Enable signal is set to zero the valve functioning is disabled (zero current to the solenoid) but the driver current output stage is still active. This condition does not comply with European Norms EN954-1.

Fault Output Signal

Fault output signal indicates fault conditions of the driver (solenoid short circuits/not connected, reference signal cable broken for 4 \div 20mA input, etc.). Fault presence corresponds to 0 Vdc, normal working corresponds to 24Vdc (pin 11 referred to pin 2): Fault status is not affected by the Enable input signal

9.3 Options /SP, /SF and /SL

These options add the closed loop control of pressure (/SP) or force (/SF and /SL) to the basic functions of proportional directional valves: a dedicated software alternates pressure (force) and valve's spool position controls depending on the actual hydraulic system conditions.

A dedicated connector is available for the additional transducers that are required to be interfaced to the valve's driver (1 pressure transducer for /SP, 2 pressure transducers for /SF or 1 load cell for /SL).

Main 12 pin connector is the same as /Z option plus two analog signals specific for the pressure (force) control: one for reference (pin 7) and one for monitor (pin 8).

For further details please refer to the driver technical table **G210, section 13**.

9.4 Options /C

Options /CSP, /CSF and /CSL are available to connect pressure (force) transducers with 4 \div 20mA current output signal.

9.5 Possible combined options: /CSP, /CSF, /CSL, /CISP, /CISF, /CISL and /IZ

10 DIGITAL INTEGRAL DRIVERS -TES - MAIN FUNCTIONS AND ELECTRONIC CONNECTIONS

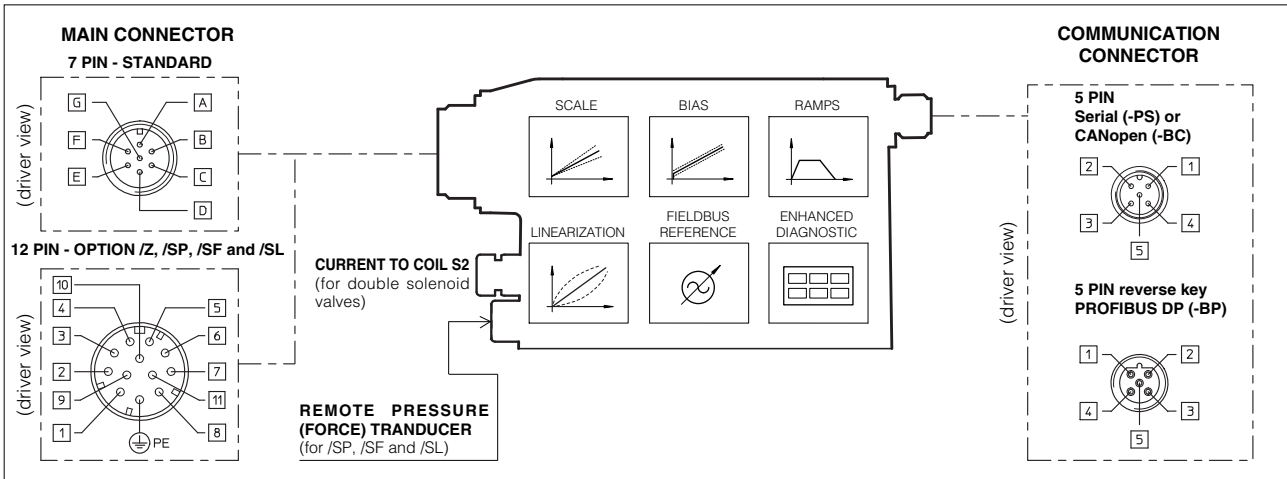

10.1 ELECTRONIC CONNECTIONS - 7 & 12 PIN MAIN CONNECTORS

Standard 7pin	/Z option 12pin	SIGNAL	TECHNICAL SPECIFICATIONS	NOTES
A	1	V+	Power supply 24 Vdc for solenoid power stage (and for driver logic on 7 pin connection)	Input - power supply
B	2	V0	Power supply 0 Vdc for solenoid power stage (and for driver logic on 7 pin connection)	Gnd - power supply
-	3	ENABLE	Enable (24 Vdc) or disable (0 Vdc) the driver	Input - on/off signal
D	4	INPUT+	Reference analog input: ± 10 Vdc maximum range ($4 \div 20$ mA for /I option) For single solenoid valves the reference input is $0 \div +10$ Vdc ($4 \div 20$ mA for /I option)	Input - analog signal
E	-	INPUT -	For double solenoid valves the reference input is ± 10 Vdc ($4 \div 20$ mA for /I option) standard: differential input; /Z option: common mode INPUT+ referred to AGND	
C	5	AGND	Ground - signal zero for MONITOR signal signal zero for INPUT+ signal (only for /Z option)	Gnd - analog signal
F	6	MONITOR	Monitor analog output: ± 10 Vdc maximum range ($4 \div 20$ mA for /I option)	Output - analog signal
-	7	NC	do not connect (pressure/force input for /SP, /SF and /SL options, see 9.3)	
-	8	NC	do not connect (pressure/force monitor for /SP, /SF and /SL options, see 9.3)	
-	9	VL+	Power supply 24 Vdc for driver logic	Input - power supply
-	10	VLO	Power supply 0 Vdc for driver logic	Gnd - power supply
-	11	FAULT	Fault (0V) or normal working (24V)	Output - on/off signal
G	PE	EARTH	Internally connected to the driver housing	

Note: A minimum time of 300 to 500 ms have to be considered between the driver energizing with the 24 VDC power supply and when the valve is ready to operate. During this time the current to the valve coils is switched to zero.

10.2 ELECTRONIC CONNECTIONS - 5 PIN COMMUNICATION CONNECTORS

PIN	-PS Serial		-BC CANopen		-BP PROFIBUS DP	
	SIGNAL	TECHNICAL SPECIFICATION	SIGNAL	TECHNICAL SPECIFICATION	SIGNAL	TECHNICAL SPECIFICATION
1	NC	do not connect	CAN_SHLD	Shield	+5V	for termination
2	NC	do not connect	NC	do not connect	LINE-A	Bus line (high)
3	RS_GND	Signal zero data line	CAN_GND	Signal zero data line	DGND	data line and termination Signal zero
4	RS_RX	Valves receiving data line	CAN_H	Bus line (high)	LINE-B	Bus line (low)
5	RS_TX	Valves transmitting data line	CAN_L	Bus line (low)	SHIELD	

11 SOFTWARE TOOLS

The functional parameters of the digital valves, as the bias, scale, ramp and linearization of the regulation characteristic, can be easily set and optimized with graphic interface by using the Atos E-SW software and the relevant USB adapters, cable and terminators, **see tab. G500**. Valves with fieldbus communication interface (-BC and -BP) can be completely managed by the machine control unit; it is required to implement in the machine control the standard communication as described in the user manuals supplied with the relevant programming software. For detailed description of available fieldbus features, **see tab. G510**

12 MAIN CHARACTERISTICS OF PROPORTIONAL DIRECTIONAL VALVES

Assembly position	Any position	
Subplate surface finishing	Roughness index, \sqrt{Ra} flatness ratio 0,01/100 (ISO 1101)	
Ambient temperature	$-20^{\circ}\text{C} \div +70^{\circ}\text{C}$ for -T execution; $-20^{\circ}\text{C} \div +60^{\circ}\text{C}$ for -TE and TES executions	
Fluid	Hydraulic oil as per DIN 51524 ... 535 for other fluids see section I	
Recommended viscosity	$15 \div 100$ mm ² /s at 40°C (ISO VG 15÷100)	
Fluid contamination class	ISO 18/15 achieved with in line filters of 10 μm and $\beta_{10} \geq 75$ (recommended)	
Fluid temperature	$-20^{\circ}\text{C} \div +60^{\circ}\text{C}$ (standard and /WG seals)	$-20^{\circ}\text{C} \div +80^{\circ}\text{C}$ (/PE seals)
Valve model	DHZO-T*	DKZOR-T*
Coil resistance R at 20°C	$3 \div 3,3 \Omega$	$3,8 \div 4,1 \Omega$
Max. solenoid current	2,6 A	3 A
Max. power	35 Watt	40 Watt
Insulation class	H (180°) Due to the occurring surface temperatures of the solenoid coils, the European standards ISO 13732-1 and EN982 must be taken into account	
Protection degree (CEI EN-60529)	IP65 for -T execution; IP65÷67 for -TE and -TES executions, depending to the connector type (see sect. I7 I9)	
Duty factor	Continuous rating (ED=100%)	

13 DIAGRAMS FOR DHZO (based on mineral oil ISO VG 46 at 50 °C)

13.1 Regulation diagrams

- 1 = linear spool L14
- 2 = linear spool L1
- 3 = progressive spool S2
- 4 = linear spool L3
- 5 = progressive spool S3, D3
- 6 = linear spool, zero overlapping OL3
- 7 = linear spool L5
- 8 = linear spool, zero overlapping OL5
- 9 = progressive spool S5, D5

Note:

Hydraulic configuration vs. reference signal for double solenoid valves (also for option /B)

- Reference signal 0 ÷ +10 V P → A / B → T
- 12 ÷ 20 mA
- Reference signal 0 ÷ -10 V P → B / A → T
- 4 ÷ 12 mA

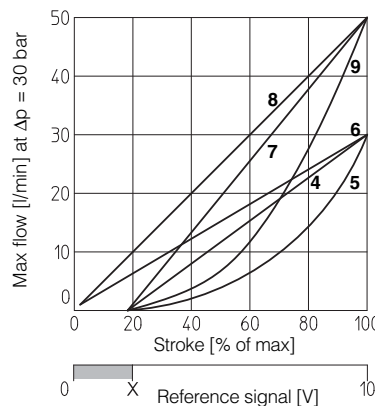
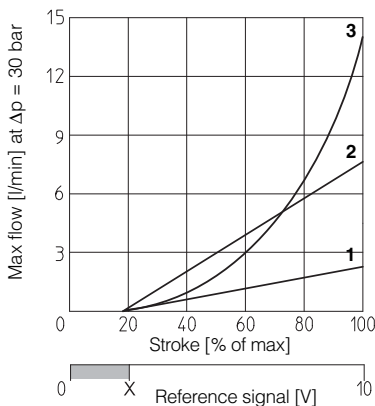

X = Threshold for bias activation depending to the valve type and amplifier type

10 = differential - linear spool V9

V9 spool type is specific for alternate P/Q controls in combination with option /SP of digital integral drivers, see tab. G210 section 13.

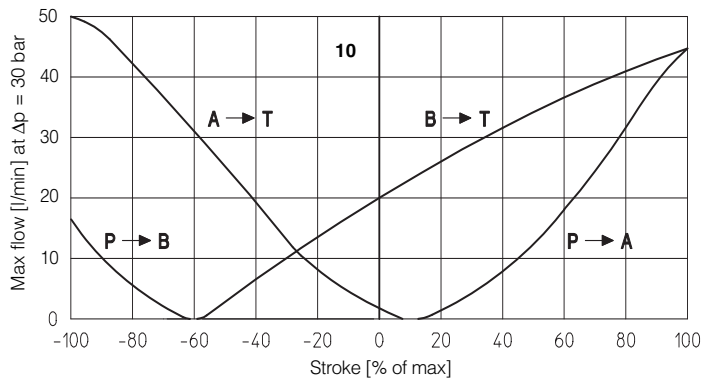

13.2 Flow /Δp diagrams

stated at 100% of valve stroke

- 1 = spool L14
- 2 = spool L1
- 3 = spool S2
- 4 = spool L3, S3, D3
- 5 = spool L5, S5, D5, V9

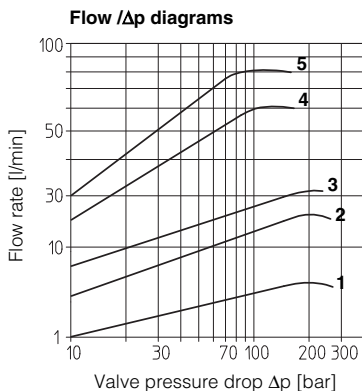

Bode diagrams

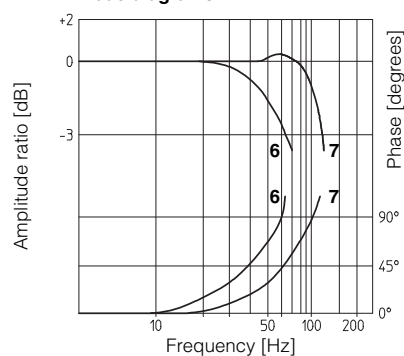

13.3 Bode diagrams

- 6 = 10% ↔ 90% nominal stroke
- 7 = 50% ± 5% nominal stroke

13.4 Operating limits

- 1 = spool L14
- 2 = spool L1
- 3 = spool S2
- 4 = spool L3, S3, D3
- 5 = spool L5, S5, D5, V9

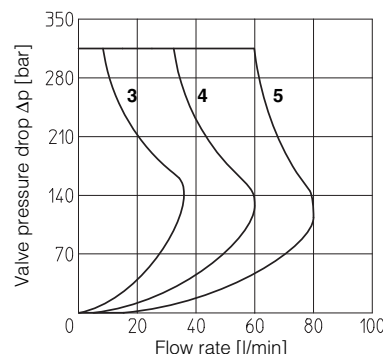
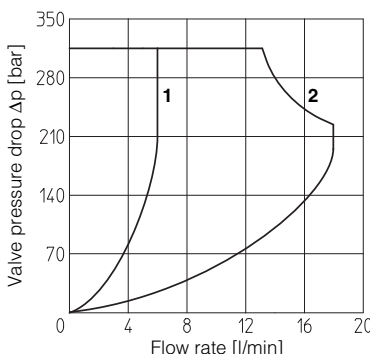

13.5 Operation as throttle valve

Single solenoid valves (DHZO-*-051) can be used as simple throttle valves: Pmax = 250 bar (option /Y advisable)

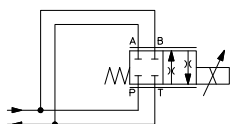

	SPOOL TYPE						
	L14	L1	S2	L3	S3	L5	S5
Max flow Δp= 70bar [l/min]	6	20	40	80	100		

13.6 Dynamic response

The response times in section 3 and the frequency responses in the bode diagrams have to be considered as average values. For the valves with digital electronics the dynamics performances can be optimized by setting the internal software parameters.

14 DIAGRAMS FOR DKZOR (based on mineral oil ISO VG 46 at 50 °C)

14.1 Regulation diagrams

- 1 = linear spool L3
- 2 = progressive spool S3, D3
- 3 = linear spool, zero overlapping 0L3
- 4 = linear spool L5
- 5 = linear spool, zero overlapping 0L5
- 6 = progressive spool S5, D5

Note:

Hydraulic configuration vs. reference signal for double solenoid valves (also for option /B)

- Reference signal 0 ÷ +10 V P → A / B → T
- 12 ÷ 20 mA
- Reference signal 0 ÷ -10 V P → B / A → T
- 4 ÷ 12 mA

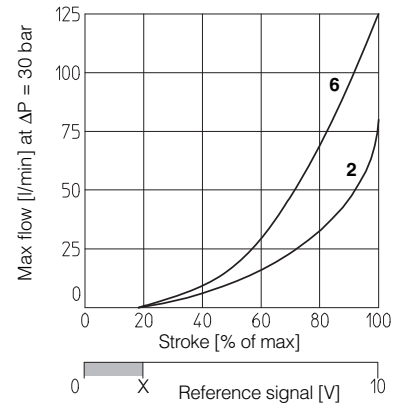
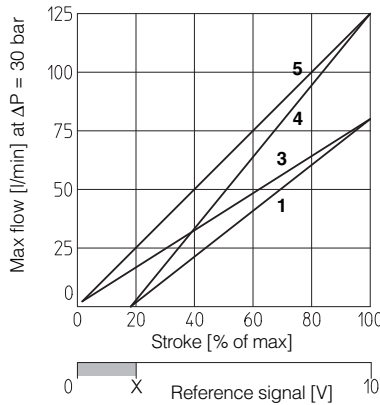

X = Threshold for bias activation depending to the valve type and amplifier type

- 7 = differential - linear spool V9

V9 spool type is specific for alternate P/Q controls in combination with option /SP of digital integral drivers, see tab. G210 section 13.

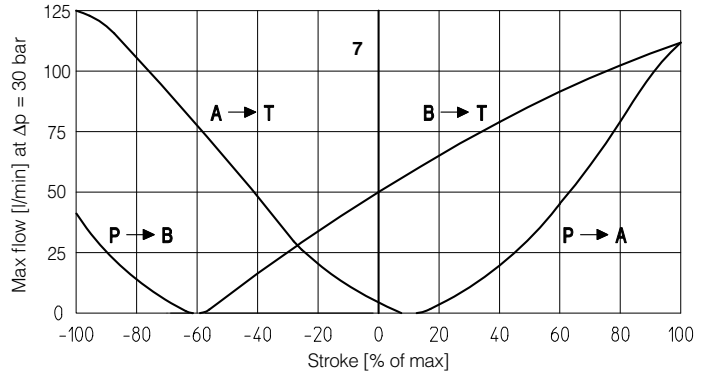

14.2 Flow /Δp diagrams

stated at 100% of valve stroke

- 1 = spool S3, L3, D3
- 2 = spool S5, L5, D5, V9

14.3 Bode diagrams

- 3 = 10% ↔ 90% nominal stroke
- 4 = 50% ± 5% nominal stroke

Flow /Δp diagrams

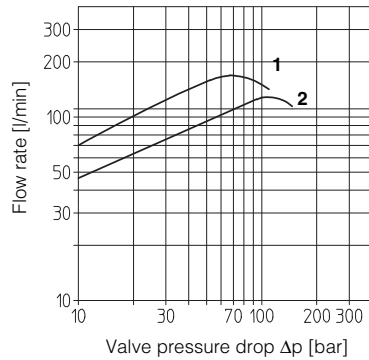

Bode diagrams

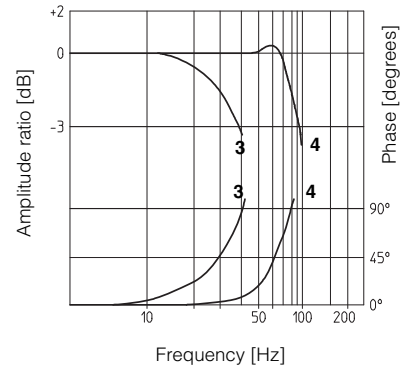

14.4 Operating limits

- 1 = spool L3, S3, D3
- 2 = spool L5, S5, D5, V9

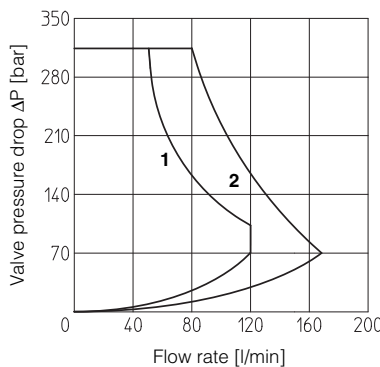

14.5 Operation as throttle valve

Single solenoid valves (DKZOR*-151) can be used as simple throttle valves: Pmax = 250 bar (option /Y advisable)

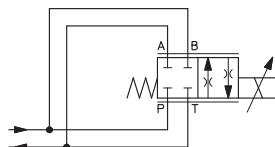

	SPOOL TYPE			
	L3	S3	L5	S5
Max flow Δp= 30 bar [l/min]	150		250	

14.6 Dynamic response

The response times in section 13 and frequency responses in the bode diagrams have to be considered as average values. For the valves with digital electronics the dynamics performances can be optimized by setting the internal software parameters.

15 INSTALLATION DIMENSIONS FOR DHZO [mm]

ISO 4401: 2000

Mounting surface: 4401-03-02-0-05 (see table P005)

(for /Y surface 4401-03-03-0-05 without X port)

Fastening bolts: 4 socket head screws M5x50 class 12.9

Tightening torque = 8 Nm

Seals: 4 OR 108; 1 OR 2025

Diameter of ports A, B, P, T: Ø 7,5 mm (max)

Diameter of port Y: Ø = 3,2 mm (only for /Y option)

DHZO-T-05

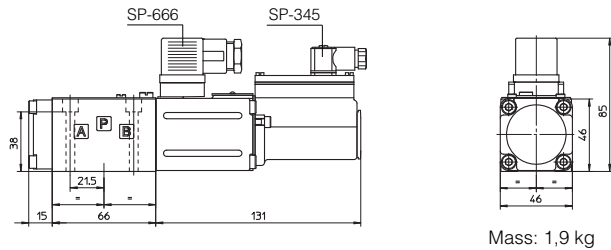

Mass: 1,9 kg

DHZO-T-07

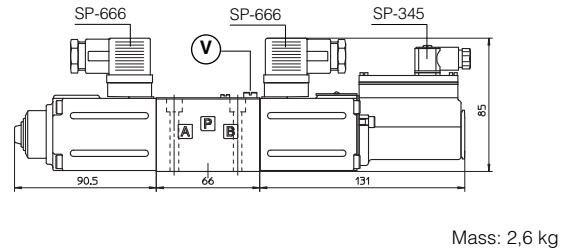

Mass: 2,6 kg

Note: for option /B the solenoid and the position transducer are at side of port A

Ⓧ = Air bleed off

-TE EXECUTION

① Dotted line = 12 pin connector SP-ZH-12P for options /K and /Z

DHZO-TE-05

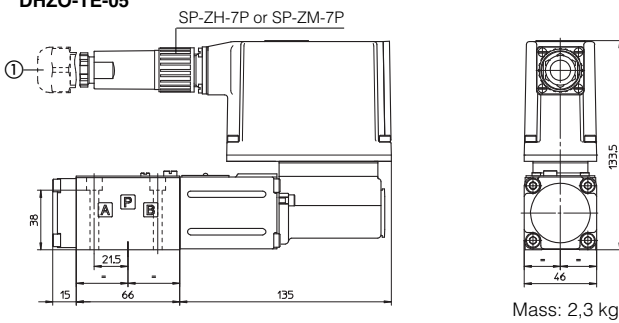

Mass: 2,3 kg

DHZO-TE-07

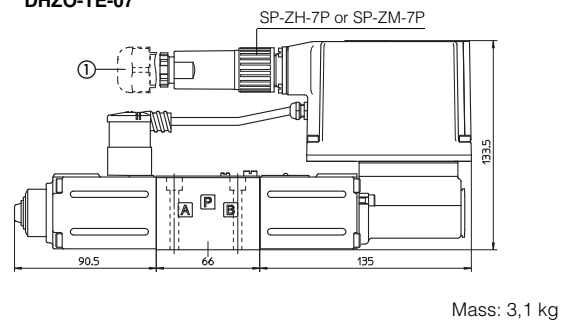

Mass: 3,1 kg

-TES EXECUTION

① Dotted line = 12 pin connector SP-ZH-12P for options /SF, /SL, /SP, /Z

② Dotted line = M8 connector SP-ZH-4P-M8/5 moulded on cable 5 mt lenght for pressure or force transducer (options /SL, /SP)

M8 connector SP-ZH-4P-M8/2-2 moulded with 2 cables, 2 mt lenght for 2 pressure transducers (options /SF)

DHZO-TES*-05

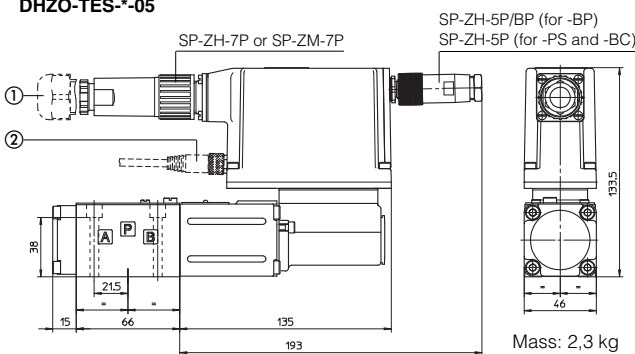

Mass: 2,3 kg

DHZO-TES*-07

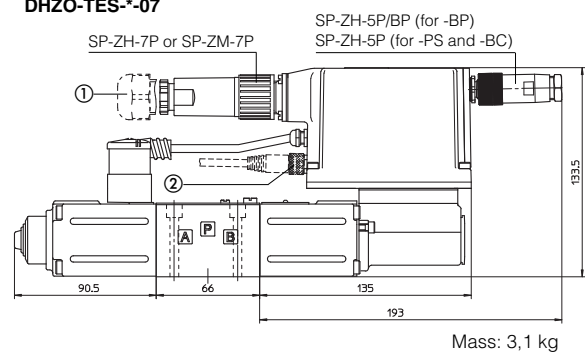

Mass: 3,1 kg

Note: for option /B the solenoid, the position transducer and the integral electronics are at side of port A

16 MODEL CODES OF POWER SUPPLY AND COMMUNICATION CONNECTORS (to be ordered separately)

VALVE VERSION	-T Power supply Transducer		-TE, -TES		-TE/K, /Z -TES /Z, /SF, /SL, /SP	TES -PS, -BC	TES -BP	TES /SF, /SL, /SP
CONNECTOR CODE	SP-666	SP-345	SP-ZH-7P	SP-ZM-7P	SP-ZH-12P	SP-ZH-5P	SP-ZH-5P/BP	SP-ZH-4P-M8/* (1)
PROTECTION DEGREE	IP65	IP65	IP67	IP67	IP65	IP67	IP67	IP67
DATA SHEET	K500		G200, G210, K500			G210, K500		

(1) M8 connector SP-ZH-4P-M8/5 moulded on cable 5 mt lenght for pressure or force transducer (options /SL, /SP)

M8 connector SP-ZH-4P-M8/2-2 moulded with 2 cables, 2 mt lenght for 2 pressure transducers (options /SF)

connectors supplied with the valve

17 INSTALLATION DIMENSIONS FOR DKZOR [mm]

ISO 4401: 2000

Mounting surface: 4401-05-04-0-05 (see table P005)
(for /Y surface 4401-05-05-0-05 without X port)

Fastening bolts: 4 socket head screws M6x40 class 12.9
 Tightening torque = 15 Nm
 Seals: 5 OR 2050; 1 OR 108
 Diameter of ports A, B, P, T: Ø 11,2 mm (max)
 Diameter of port Y: Ø = 5 mm (only for /Y option)

DKZOR-T-15

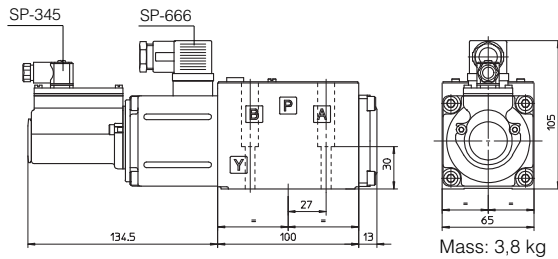

Mass: 3,8 kg

DKZOR-T-17

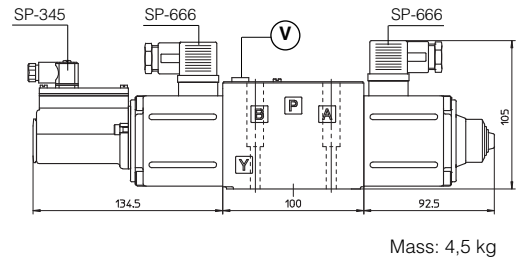

Mass: 4,5 kg

Note: for option /B the solenoid and the position transducer are at side of port A

(V) = Air bleed off

-TE EXECUTION

① Dotted line = 12 poles connector SP-ZH-12P for options /K and /Z

DKZOR-TE-15

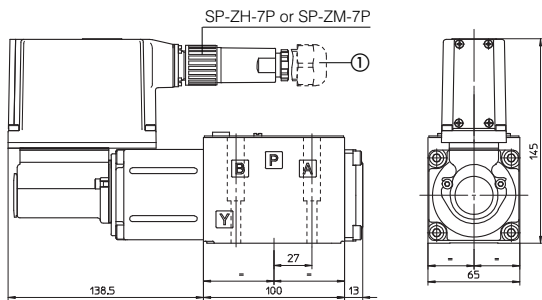

Mass: 4,3 kg

DKZOR-TE-17

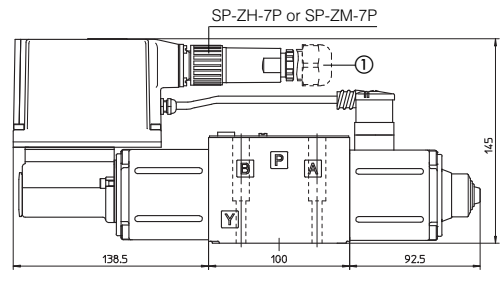

Mass: 5,0 kg

-TES EXECUTION

① Dotted line = 12 pin connector SP-ZH-12P for options /SF, /SL, /SP, /Z
 ② Dotted line = M8 connector SP-ZH-4P-M8/5 moulded on cable 5 mt length for pressure or force transducer (options /SL, /SP)
 M8 connector SP-ZH-4P-M8/2-2 moulded with 2 cables, 2 mt length for 2 pressure transducers (options /SF)

DKZOR-TES*-15

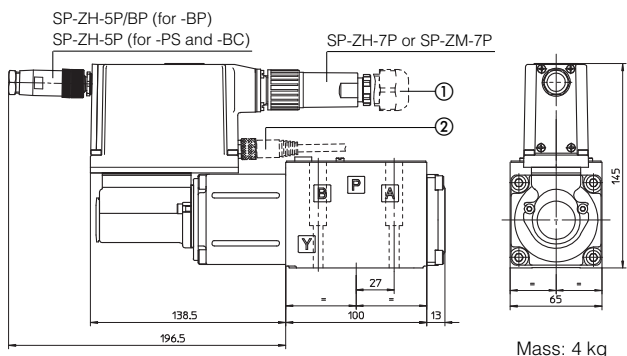

Mass: 4 kg

DKZOR-TES*-17

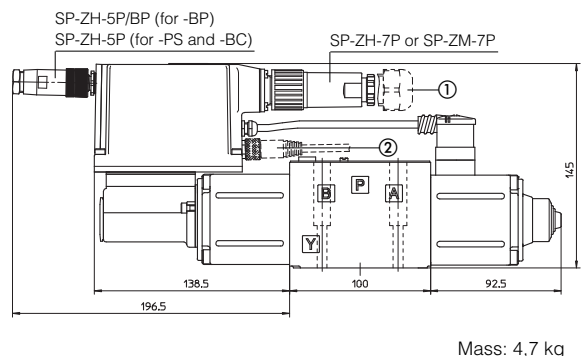

Mass: 4,7 kg

Note: for option /B the solenoid, the position transducer and the integral electronics are at side of port A

18 MODEL CODES OF POWER SUPPLY AND COMMUNICATION CONNECTORS (to be ordered separately)

VALVE VERSION	-T Power supply Transducer		-TE, -TES		-TE/K, /Z -TES /Z, /SF, /SL, /SP	TES -PS, -BC	TES -BP	TES /SF, /SL, /SP
CONNECTOR CODE	SP-666	SP-345	SP-ZH-7P	SP-ZM-7P	SP-ZH-12P	SP-ZH-5P	SP-ZH-5P/BP	SP-ZH-4P-M8* (1)
PROTECTION DEGREE	IP65	IP65	IP67	IP67	IP65	IP67	IP67	IP67
DATA SHEET	K500		G200, G210, K500			G210, K500		

(1) M8 connector SP-ZH-4P-M8/5 moulded on cable 5 mt length for pressure or force transducer (options /SL, /SP)
 M8 connector SP-ZH-4P-M8/2-2 moulded with 2 cables, 2 mt length for 2 pressure transducers (options /SF)

connectors supplied with the valve